



# SI-BAM21-LC

*KG Optical Force Transducer Amplifier*

## **INSTRUCTION MANUAL**

Serial No. \_\_\_\_\_

040214

[www.wpiinc.com](http://www.wpiinc.com)

**CONTENTS**

ABOUT THIS MANUAL .....	1
INTRODUCTION .....	2
Features .....	2
How the Amplifier Works.....	2
Notes and Warnings .....	2
Parts List .....	3
Unpacking .....	3
INSTRUMENT DESCRIPTION.....	4
Front Panel .....	4
Back Panel.....	5
Setup.....	5
OPERATING INSTRUCTIONS.....	6
Calibrating the SI-BAM21-LC .....	6
Making Measurements .....	9
MAINTENANCE.....	10
ACCESSORIES.....	10
TROUBLESHOOTING.....	11
SPECIFICATIONS.....	11
APPENDIX A: SETTING SYSTEM GAIN FACTOR.....	12
INDEX.....	13
WARRANTY .....	15
Claims and Returns .....	15
Repairs .....	15

*Copyright © 2014 by World Precision Instruments, Inc. All rights reserved. No part of this publication may be reproduced or translated into any language, in any form, without prior written permission of World Precision Instruments, Inc.*



## ABOUT THIS MANUAL

The following symbols are used in this guide:



This symbol indicates a CAUTION. Cautions warn against actions that can cause damage to equipment. Please read these carefully.



This symbol indicates a WARNING. Warnings alert you to actions that can cause personal injury or pose a physical threat. Please read these carefully.

NOTES and TIPS contain helpful information.



Fig. 1—SI-BAM21-LC KG Optical Force Transducer Amplifier

---

## INTRODUCTION

The **SI-BAM21-LC** KG Optical Force Transducer Amplifier is used in conjunction with the SI-H Muscle Bath system and the related line of SI-Heidelberg muscle physiology products. The **SI-BAM21-LC** powers the force transducer and outputs an analog voltage proportional to the force applied to the force transducer. The force feedback signal can be multiplied by a factor of 1, 2, 5 or 10 to provide better resolution for a minimal change in applied force.

**NOTE:** An optional factory setting increases the multiplier by a factor of 10, allowing the signal to be multiplied by 10, 20, 50 and 100.

## Features

The **SI-BAM21-LC** is a KG optical force transducer amplifier that:

- Supplies an analog output (-10VDC to +10VDC) representing the force applied to the tissue sample.
- Delivers a DC power supply voltage to the force transducer.

## How the Amplifier Works

In a typical setup, a muscle is held by a force transducer and suspended in a tissue bath. The force transducer is connected to the **SI-BAM21-LC**. As the muscle contracts or releases, the force transducer converts the force into an electrical current signal which is proportional to the force applied to the force transducer.

Before initiating an experiment, the **SI-BAM21-LC** must first be zeroed. This sets the baseline for measurements to follow.

The output signal is buffered and multiplied by 1, 2, 5 or 10, depending on the front panel **Gain** switch setting. The X10 setting is useful when output signals are extremely small. Finally, the force proportional signal is sent through the output amplifier circuit.

The analog output has a range of -10V to +10V that drives a data acquisition system, multimeter or oscilloscope.

## Notes and Warnings

**NOTE:** This system is designed for use exclusively with the SI-H line of KG force transducers. It is not configured for use with the SI-H MicroTweezer or other types of force transducers.

## Parts List

After unpacking, verify that there is no visible damage to the instrument. Verify that all items are included:

- (1) **SI-BAM21-LC** KG Optical Force Transducer Amplifier
- (1) Universal input (100-120VAC to 200-240VAC) AC adapter
- (1) Power cord
- (1) **13661** Potentiometer Adjustment Tool
- (1) Instruction Manual

## Unpacking

Upon receipt of this instrument, make a thorough inspection of the contents and check for possible damage. Missing cartons or obvious damage to cartons should be noted on the delivery receipt before signing. Concealed damage should be reported at once to the carrier and an inspection requested. Please read the section entitled "Claims and Returns" on page 15 of this manual. Please contact WPI Customer Service if any parts are missing at 941.371.1003 or [customerservice@wpiinc.com](mailto:customerservice@wpiinc.com).

**Returns:** Do not return any goods to WPI without obtaining prior approval (RMA # required) and instructions from WPI's Returns Department. Goods returned (unauthorized) by collect freight may be refused. If a return shipment is necessary, use the original container, if possible. If the original container is not available, use a suitable substitute that is rigid and of adequate size. Wrap the instrument in paper or plastic surrounded with at least 100mm (four inches) of shock absorbing material. For further details, please read the section entitled "Claims and Returns" on page 15 of this manual.

---

# INSTRUMENT DESCRIPTION

## Front Panel

The front panel of the **SI-BAM21-LC** is shown in **Fig. 2**.

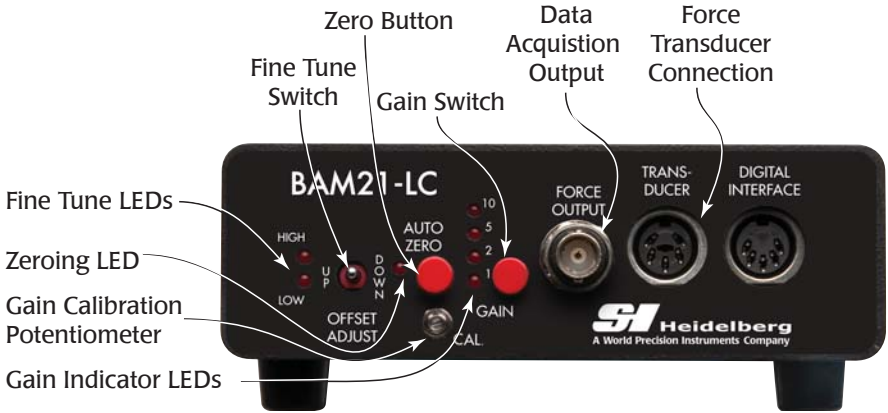

*Fig. 2—Front panel of the SI-BAM21-LC*

**Zero Button**—When pressed, the **SI-BAM21-LC** output comes close to zero and the **Zeroing LED** illuminates. Before any measurements are taken, the **SI-BAM21-LC** should be zeroed to establish a baseline value for the force transducer.

**Fine Tune Switch**—This toggle switch allows you to fine tune the system after zeroing. Press and hold the toggle switch to the left if you want to raise the baseline. Or, press and hold the toggle switch to the right to lower the baseline. If the baseline is more than 0.3V above zero, the High LED illuminates, and if it is less than -0.3V, the Low LED illuminates. When the baseline is within 0.3V of zero, the LEDs are off.

**Gain Switch**—Under normal conditions, the **Gain** switch is set to X1. The current output of the force transducer can be amplified by a factor of 2, 5 or 10. Press the **Gain** switch to toggle between the gain settings. A **Gain Indicator LED** illuminates to show which gain factor is applied. Larger gains are essential when working with extremely small forces.

**Gain Calibration Potentiometer**—Adjusting this potentiometer defines the gain applied. Use the provided potentiometer adjustment tool (WPI #13661) to calibrate the output voltage scale factor to the force transducer current. See “Calibrating the **SI-BAM21-LC**” on page 6.

**Data Acquisition Output**—Connect a data acquisition system like WPI’s **Lab-Trax** to this BNC connector to record the **SI-BAM21-LC** voltage output. For test purposes, a multi-meter or oscilloscope may be connected using a standard BNC cable (WPI #2851).

**Force Transducer Connection**—A SI-KG series force transducer is plugged into this DIN connector. Align the pins, and insert the connector until it is fully seated.

**Digital Interface**—This connection is reserved for future use with an anti-oscillation unit.

## Back Panel

The back panel of the **SI-BAM21-LC** is shown in **Fig. 3**.

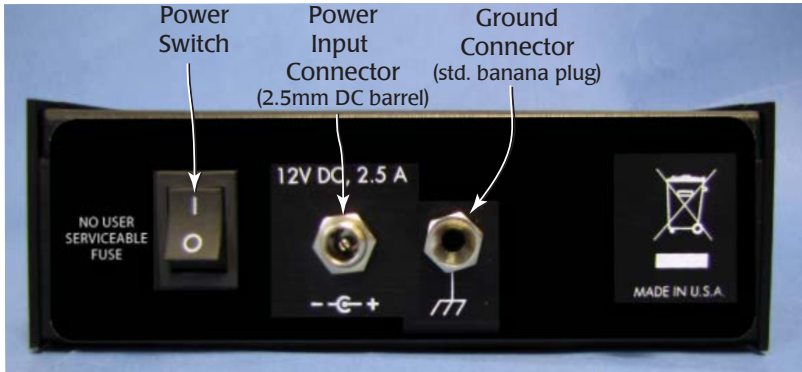

Fig. 3—Back panel of the SI-BAM21-LC

**Power Switch**—This toggle switch turns the power off (0) and on (I).

**Power Input Connector**—Plug the power cord into this connector.

**Ground Connector**—Use a ground wire with standard banana plug connector in this socket to ground the entire unit to the desired reference.

## Setup

Once the instrument has been inspected and accessories accounted for, make the cable connections for system interfaces as shown in **Fig. 4**.

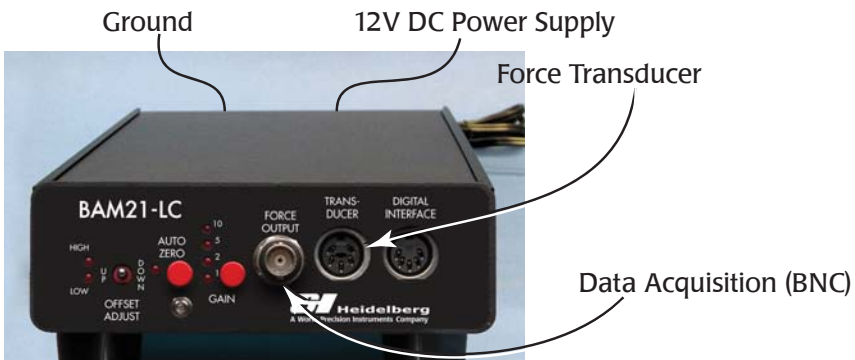

Fig. 4—SI-BAM21-LC Connections



1. Connect the force transducer cable to the **Force Transducer** connection port (labeled **Transducer**) on the front of the **SI-BAM21-LC**. Align the pins and insert the connector.
2. Connect a BNC cable from the data acquisition system input to the **Output** on the front panel of the **SI-BAM21-LC**.
3. Connect the AC power adapter to the **Power Input** (labeled **12V DC, 2.5A**) on the back panel of the **SI-BAM21-LC**.
4. Turn the **Power** switch on the back panel on (I).

## OPERATING INSTRUCTIONS

### Calibrating the SI-BAM21-LC

Before taking measurements, the **SI-BAM21-LC** must be calibrated. Each **SI-KG** force transducers shown responds linearly within its respective measurement ranges. Consequently, the **SI-BAM21-LC** can be calibrated using only two reference points.

Force Transducer	Force Range	Range (g)	Noise ( $\mu\text{N}$ )	Compliance (nm/mN)	Resonance Frequency
SI-KG2	0-2N	0-200	250	150	1.3kHz
SI-KG2A	0-0.5N	0-50	300		
SI-KG4	0-50mN	0-5	15	0.5	1.2kHz
SI-KG4A	0-20mN	0-2	4	1	1.2kHz
SI-KG7	0-5mN	0-0.5	0.2	10	250Hz
SI-KG7A	0-5mN	0-0.5	0.4	5	500Hz
SI-KG7B	0-10mN	0-1.0	1	1.5	550Hz
SI-KG20	0-0.2N	0-20	80 $\mu\text{N}$		590Hz

Under ideal conditions, use a model of **SI-KG** transducer that has a full-load range that is no more than 120% of the maximum force that is anticipated. For example, if the greatest force to be measured is 4g, use a transducer that has a full-load range of 5g, like the **SI-KG4** transducer. To use the transducer at its full-load range, set the gain of the **SI-BAM21LCB** to X1. Higher resolutions are possible using the other gain settings (X2, X5, or X10). However, using a gain of X10 allows only a tenth of the full-load range of the transducer to be displayed as an output. In general, it is best to choose a gain factor that does not need to be changed during an experiment, since each gain factor can have slight variances in its offset. If it is necessary to switch between gain ranges during an experiment, check the offsets in each of the ranges after the calibration and before conducting the experiment. Then, use the **Offset Adjustment** switch to set the minimum average offset between the ranges.

**NOTE:** Before calibrating the **SI-KG** transducer, position the tissue mount being used on the actuator rod of the transducer. During the calibration, place the weight on the tissue mount at the same position where the tissue will be attached.

The basic procedure for calibrating the **SI-BAM21-LC** involves:

1. Setting a zero reference point with the force transducer un-loaded.
2. Applying a load with a known mass to the tissue mount on the transducer.
3. Choosing one of the two calibration methods that best serves the application. Use the **Gain Calibration Potentiometer** to adjust the amplifier's output range to:
  - Maximize the resolution for the intended measurement range. For the greatest precision, maximize the resolution of the **SI-BAM21-LC** by calibrating the 10.0V output of the amplifier to 10-20% above the maximum expected force. For example, if the maximum expected value is 4.0-4.5g, set the **SI-BAM21-LC** so that a 5g mass yields a 10.0V output. The maximum expected output would then be 9.0V, with a 4.5g applied load.
  - Numerically correlate the force with a voltage output. For quick visualization, you may choose to establish a numerical correlation by calibrating the **SI-BAM21-LC** so that a force like 5.0g generates a 5.0V output.

The following calibration procedure may be used with any **SI-KG** force transducer. For illustration purposes, a **SI-KG4** force transducer is used in the example. Note that a 5g mass is the maximum force that a **SI-KG4** can measure. If a gain of X10 is used with the **SI-KG4** transducer, then 0.5g, which is about 10% of the total range of the **SI-KG4** force transducer, is the largest mass that can be used with this force sensor.

1. Connect the force transducer to the transducer input of the **SI-BAM21-LC**. Connect the output of the **SI-BAM21-LC** to an input of a data acquisition system or a digital multimeter. See "Setup" on page 5.
  - If a multimeter is used to track the output of the amplifier, set the scale of the meter to measure DC voltages between -10.0 and +10.0VDC.
  - If a computerized data acquisition system, like a LabTrax 8/16, is used to record the output of the amplifier, use the autoscale feature of the recording software to track the changes in the output voltage as the calibration is performed.
2. Mount the force transducer on the calibration stand on the base of the **SI-MT**, **SI-MKB** or **SI-HTB** system.

**NOTE:** The calibration stand holds the force transducer and its tissue mount in the proper orientation for an accurate calibration. This angle is critical in establishing a proper calibration ratio. When gravity pulls the mass hung on end of the tissue mount down, the actuator rod of the transducer is pulled in the same direction as the force created by the tissue used in the experiment. If the force is not pulling on the tissue mount in this direction, the output signal has to be adjusted correspondingly.

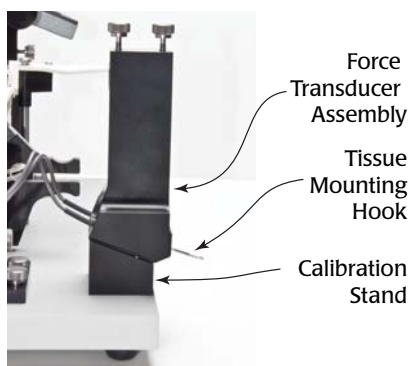

Fig. 5—When the force transducer is properly mounted in the calibration stand on the muscle tester, the force transducer is held at the same angle used when making measurements.

3. Set the **Gain** switch on the front panel of the **SI-BAM21-LC** to the gain (X1-X10) that is suitable for the mass being used for the calibration of the selected transducer.
4. With no weight suspended from the transducer, press and release the **Zero** button on the **SI-BAM21-LC**. Use the multimeter or data acquisition system to monitor the transducer output signal from the **SI-BAM21-LC**. A reading of  $0.0\text{VDC} \pm 50\text{mV}$  should be seen. Remember that the zeroing error is larger with higher gains. Use the **Offset Adjustment** switch to move the baseline of the recording closer to zero if a smaller offset error is desired.

**NOTE:** When the **Zero** button is pressed, the zeroing LED illuminates to indicate that the zeroing function is processing.

5. Use the **Offset Adjustment** switch to adjust the baseline to zero. Press and hold the toggle switch to the left, if you want to raise the baseline. Or, press and hold the toggle switch to the right to lower the baseline. If the baseline is more than 0.3V above zero, the **High LED** illuminates, and if it is less than  $-0.3\text{V}$ , the **Low LED** illuminates. When the baseline is within 0.3V of zero, the LEDs are off.

**NOTE:** Once the baseline is zeroed to the desired position, *do not touch* the **Offset Adjustment** switch until the calibration procedure is completed.

6. From the point on the tissue mount of the transducer where the tissue will be attached, suspend a known mass that is close to the maximum range for the amplification factor and force transducer being used. In the example for the **SI-KG4** force transducer, a weight less than 5.0g is used for X1 or less than 0.5g for X10.

**NOTE:** Mass in grams can be converted to force in Newtons (N) by multiplying the weight hung on the transducer by gravitational acceleration. Since force

equals mass times acceleration ( $F=ma$ ), a 0.5g weight is equal to 4.9mN ( $0.0005\text{kg} * 9.8\text{m/s}^2 = 0.0049\text{N}$ ). Make sure that the mass used to calibrate the transducer amplifier creates a force that falls within the operating range of the force transducer and amplification factor you selected.

7. After the suspended mass becomes motionless, monitor the output of the amplifier while adjusting the **Gain Calibration** potentiometer on the **SI-BAM21-LC**. Use a potentiometer adjustment tool to adjust the **Gain Calibration** potentiometer to any desired value up to the limit of 10.0V.
8. If you intend to use multiple amplification factors, cross-check your calibration. For example, if a 0.5g mass was used to calibrate the **SI-BAM21-LC** as close as possible to 10.0V at a gain of X10, then at a gain of X1, the monitor should display an output very close to 1.0V for the same 0.5g calibration mass.

## Making Measurements

After the **SI-BAM21-LC** has been calibrated, measurements may be taken.

1. Turn the **SI-BAM21-LC Power** switch on (I).

**NOTE:** Allow the system to stabilize for about 30 minutes. This allows all the components to reach thermal equilibrium, minimizing measurement changes due to thermal variations.

2. Turn on the data acquisition system.
3. Press the **Zero** button to set the baseline value for the measurements.

**NOTE:** When the **Zero** button is pressed, the zeroing LED illuminates to indicate that it is functioning properly.

4. Measurements may be taken.

---

## MAINTENANCE

The **SI-BAM21-LC** is maintenance free. However, to protect your **SI-BAM21-LC**, follow these guidelines:

- Place the **SI-BAM21-LC** in a clean, dry location.
- Use only a 12V DC, 2.5A power supply.
- Keep liquids away from the **SI-BAM21-LC** connections.

## ACCESSORIES

Part Number	Description
13661	Potentiometer Adjustment Tool (Tweaker)
2851	BNC Cable
801513	Universal Input Power Supply AC Adapter
801514	Power Cord for AC Adapter, US plug
SI-DAS	SI-H Data Acquisition/Analysis System
SI-KG2	0-2N Force Transducer
SI-KG2A	0-0.5N Force Transducer
SI-KG4	0-50mN Force Transducer
SI-KG4A	0-20mN Force Transducer
SI-KG7	0-5mN Force Transducer
SI-KG7A	0-5mN Force Transducer
SI-KG7B	0-10mN Force Transducer
LAB-TRAX-4	4-Channel Data Acquisition System
SI-MT-L	Muscle Tester with long cuvette
SI-MT-S	Muscle Tester with short cuvette
SI-MT-O	Muscle Tester with optical cuvette
SI-FS	Electrode for field stimulation

## TROUBLESHOOTING

Issue	Possible Cause	Solution
No output Signal (0.0V DC)	Poor force transducer connection	Verify that the cables are securely connected.
	BNC cable is bad	Try substituting a different BNC cable to troubleshoot the cause.
	Transducer failed	Try substituting a different force transducer to troubleshoot the cause.

**NOTE:** If you have a problem/issue with that falls outside the definitions of this troubleshooting section, contact the WPI Technical Support team at 941.371.1003 or [technicalsupport@wpiinc.com](mailto:technicalsupport@wpiinc.com).

## SPECIFICATIONS

The **SI-BAM21-LC** conforms to the following specifications:

Input Configuration	Current to voltage converter
Gain	1X, 2X, 5X, 10X - Switch slectable
Output Impedance	470 Ohm
Power Requirements	12V DC at 2.5A (wall adaptor included– WPI # <b>801513</b> ), 2.5mm DC barrel
Output Range	±10V DC

---

## APPENDIX A: SETTING SYSTEM GAIN FACTOR

The **SI-BAM21-LC** gain multiplier setting is selected with an internal jumper that is configured at the factory for use with the muscle tester system of your choice (**SI-MT**, **SI-MKB**, **SI-HTB**). The **X1** setting (**SI-MT/SI-HTB**) allows for 1X, 2X, 5X and 10X gains. The **X10** setting (**SI-MKB**) allows for 10X, 20X, 50X and 100X gains that may be needed when recording passive tension or small muscle contractions.

1. Turn off the **SI-BAM21-LC** and unplug it from the power outlet.
2. Remove the four screws on the lid of the **SI-BAM21-LC** unit.

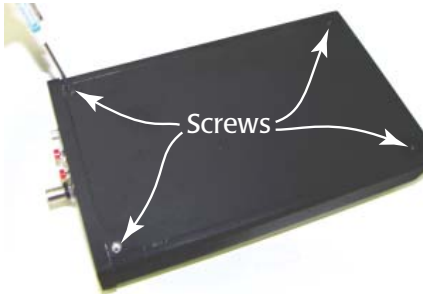

Fig. 6—The screws are identified on the top of the box.

3. Remove the lid from the amplifier.



Fig. 7—If you tip the box upside down, the back end of the lid opens and you can slide it off the box.

4. Locate the 3-pin jumper J16. Jumper pins 1 and 2 to use the **SI-BAM21-LC** with the **X1** gain multiplier, or jumper pins 2 and 3 for use with the **X10** gain multiplier.
5. Reinstall the lid on the unit and secure it with the screws.

## INDEX

### A

AC adapter 3

### B

back panel 5  
banana plug 5

### C

calibration potentiometer 5

### F

force transducer 2, 4, 5, 6, 11  
front panel 4

### G

ground 5

### M

maintenance 10  
measurements 9  
MicroTweezer 2

### O

output 4, 6

### P

parts list 3  
power 5

### R

returns 3

### S

specifications 11

### T

troubleshooting 11  
tweaker 10

### U

unpacking 3

### Z

zero switch 4





**WORLD PRECISION INSTRUMENTS, INC.**

175 Sarasota Center Boulevard  
Sarasota, FL 34240-9258 USA  
Telephone: (941) 371-1003 Fax.: (941) 377-5428  
e-mail: [wpi@wpiinc.com](mailto:wpi@wpiinc.com)

**DECLARATION OF CONFORMITY**

We: World Precision Instruments, Inc.  
175 Sarasota Center Boulevard  
Sarasota, FL 34240-9258 USA

As the manufacture of the apparatus listed, declare under sole responsibility  
that the product(s):  
SI-BAM21-LC KG Optical Force Transducer Amplifier

To which this declaration relates is/are in conformity with the following standards  
or other normative documents:

**Safety:** EN 61010-1:2010  
**Emc:** EN 61326-2-3:2006  
EN 61326:1997+A1:1998+A2:2001+A3:2003

And therefore conform(s) with the protection requirements of Council Directive  
2004/108/EC relating to electromagnetic compatibility and Council Directive  
2006/95/EC relating to safety requirements:

Issued on: July 7<sup>th</sup>, 2011

  
**Cliff Bredenberg**  
**President**

World Precision Instruments, Inc.  
175 Sarasota Center Boulevard  
Sarasota, FL 34240-9258 USA

  
**Glen Carlquist**

**Vice President of Production**  
World Precision Instruments, Inc.  
175 Sarasota Center Boulevard  
Sarasota, FL 34240-9258 USA

## **WARRANTY**

WPI (World Precision Instruments, Inc.) warrants to the original purchaser that this equipment, including its components and parts, shall be free from defects in material and workmanship for a period of 30 days\* from the date of receipt. WPI's obligation under this warranty shall be limited to repair or replacement, at WPI's option, of the equipment or defective components or parts upon receipt thereof f.o.b. WPI, Sarasota, Florida U.S.A. Return of a repaired instrument shall be f.o.b. Sarasota.

The above warranty is contingent upon normal usage and does not cover products which have been modified without WPI's approval or which have been subjected to unusual physical or electrical stress or on which the original identification marks have been removed or altered. The above warranty will not apply if adjustment, repair or parts replacement is required because of accident, neglect, misuse, failure of electric power, air conditioning, humidity control, or causes other than normal and ordinary usage.

To the extent that any of its equipment is furnished by a manufacturer other than WPI, the foregoing warranty shall be applicable only to the extent of the warranty furnished by such other manufacturer. This warranty will not apply to appearance terms, such as knobs, handles, dials or the like.

WPI makes no warranty of any kind, express or implied or statutory, including without limitation any warranties of merchantability and/or fitness for a particular purpose. WPI shall not be liable for any damages, whether direct, indirect, special or consequential arising from a failure of this product to operate in the manner desired by the user. WPI shall not be liable for any damage to data or property that may be caused directly or indirectly by use of this product.

## **Claims and Returns**

Inspect all shipments upon receipt. Missing cartons or obvious damage to cartons should be noted on the delivery receipt before signing. Concealed loss or damage should be reported at once to the carrier and an inspection requested. All claims for shortage or damage must be made within ten (10) days after receipt of shipment. Claims for lost shipments must be made within thirty (30) days of receipt of invoice or other notification of shipment. Please save damaged or pilfered cartons until claim is settled. In some instances, photographic documentation may be required. Some items are time-sensitive; WPI assumes no extended warranty or any liability for use beyond the date specified on the container

Do not return any goods to us without obtaining prior approval and instructions from our Returns Department. Goods returned (unauthorized) by collect freight may be refused. Goods accepted for restocking will be exchanged or credited to your WPI account. Goods returned which were ordered by customers in error are subject to a 25% restocking charge. Equipment which was built as a special order cannot be returned.

## **Repairs**

Contact our Customer Service Department for assistance in the repair of apparatus. Do not return goods until instructions have been received. Returned items must be securely packed to prevent further damage in transit. The Customer is responsible for paying shipping expenses, including adequate insurance on all items returned for repairs. Identification of the item(s) by model number, name, as well as complete description of the difficulties experienced should be written on the repair purchase order and on a tag attached to the item.

*\* Electrodes, batteries and other consumable parts are warranted for 30 days only from the date on which the customer receives these items.*



## ***World Precision Instruments, Inc.***

### **USA**

International Trade Center, 175 Sarasota Center Blvd., Sarasota FL 34240-9258  
Tel: 941-371-1003 • Fax: 941-377-5428 • E-mail: sales@wpiinc.com

### **UK**

1 Hunting Gate, Hitchin, Hertfordshire SG4 0TJ  
Tel: 44 (0)1462 424700 • Fax: 44 (0)1462 424701 • E-mail: wpiuk@wpi-europe.com

### **Germany**

Zossener Str. 55, 10961 Berlin  
Tel: 030-6188845 • Fax: 030-6188670 • E-mail: wpide@wpi-europe.com

### **China & Hong Kong**

WPI Shanghai Trading Co., Ltd.  
Rm 29a, No8 Dongfang Rd., Pudong District, Shanghai, 200120 PR China  
Tel: +86 21 6888 5517 • E-mail: chinasales@china.wpiinc.com

### **Internet**

www.wpiinc.com • www.wpi-europe.com • www.wpiinc.cn