

LAMBDA LS

XENON ARC LAMP
ILLUMINATOR SYSTEM

OPERATION MANUAL

REV. 3.02 (20110803)



SUTTER INSTRUMENT

ONE DIGITAL DRIVE
NOVATO, CA 94949

VOICE: 415-883-0128 WEB: WWW.SUTTER.COM
FAX: 415-883-0572 EMAIL: INFO@SUTTER.COM



Copyright © 2011 Sutter Instrument Company. All Rights Reserved.

LAMBDA 10[®] is a registered trademark, and SmartShutter[™] is a trademark, both of Sutter Instrument Company.

DISCLAIMER

The xenon arc lamp Lambda LS is designed for the specific use as a microscope illuminator and no other use is recommended.

This instrument should only be used in a laboratory environment. It is not intended for, nor should it be used in, human experimentation or applied to humans in any way. This is not a medical device.

Do not open or attempt to repair the instrument without expressed and explicit instructions from Sutter Instrument Company. Extreme heat and high voltages are present and could cause injury.

Do not allow unauthorized and or untrained operatives to use this device.

Any misuse will be the sole responsibility of the user/owner and Sutter Instruments assumes no implied or inferred liability for direct or consequential damages from this instrument if it is operated or used in any way other than for which it is designed.



SAFETY WARNINGS AND PRECAUTIONS

Electrical

- Operate the Lambda LS using 110-120 V AC, 60 Hz, or 220-240 V AC., 50 Hz line voltage. This instrument is designed for connection to a standard laboratory power outlet (Overvoltage Category II). A surge protector and power regulator are recommended.
-  **Fuse Replacement:** Replace only with the same type and rating:
5 Amp, 250V, 5 x 20mm, Time Delay fuse (EIC 60127-2)
(Examples: Bussmann GDC-5A or S506-5A (RoHS), or
Littelfuse 218.005 or 218.005.P (RoHS))

A spare fuse is located in the power input module. Please refer to APPENDIX C for more details on fuse ratings and for instructions on how to change the fuse.

Avoiding Electrical Shock and Fire-related Injury

-  Always use the grounded power supply cord set provided to connect the system to a grounded outlet (3-prong). This is required to protect you from injury in the event that an electrical hazard occurs.
- Do not disassemble the system. The only user serviceable parts are the line fuse, the xenon bulb, and the filter wheel (if installed). The line fuse is accessible from the outside of the system. The bulb and the filter wheel are accessible via separate panels on the top of the unit. Bulb replacement and filter wheel installation/removal are covered in separate sections of the manual and should only be attempted with the power cord disconnected.
-  To prevent fire or shock hazard do not expose the unit to rain or moisture.



Operational

- Operate only in a location where there is a free flow of fresh air on all sides. NEVER ALLOW THE FREE FLOW OF AIR TO BE RESTRICTED.
- Do not operate the lamp in an orientation where the output of the CERMAX lamp faces within 45° of straight upward. To do so may cause arc instability and the possibility of damage to the front window of the CERMAX lamp. Note that the lamp output is towards the heat sink mounted on the side of the cabinet.

Avoiding Physical Injury while Powered up and Emitting Light



WARNING: DO NOT LOOK DIRECTLY INTO THE OUTPUT OF THE LIGHT APERTURE OR LIGHT GUIDE! *The output of the light aperture or the light guide should be directed into the microscope using the appropriate adapters, directed away from anyone's eyes, and not directed toward any reflective surface.*

-  **INFRARED RADIATION:** The infrared radiation (and ultraviolet radiation) generated by this lamp can cause significant skin burns and eye damage.
-  **EXPLOSION:** High internal pressure exists in any xenon arc lamp.
-  **HIGH VOLTAGE:** High ignition voltages, which exist inside the cabinet, can be lethal.



WARNING – OZONE: *The UV-enhanced (“full spectrum”) version of the xenon arc bulb generates significant amounts of ozone, which is toxic. A Lambda-LS installed with a full spectrum bulb must be connected to a ventilation or ozone-removing system (also known as an “ozone eater”) for the evacuation of the ozone produced during operation. Please contact Sutter Instrument (+1-415-883-0128 or info@sutter.com) for further information. There are no ventilation requirements for the ozone-free bulb.*

The original manufacturer of the xenon lamp and power supply used in the Lambda LS provides the additional safety information on the following page. It is intended to amplify the information given above.



PerkinElmer Optoelectronics
 44370 Christy Street
 Fremont CA 94538
 Phone: 510-979-6500
 FAX: 510-687-1152



OPERATING HAZARDS

CERMAX® Lamps

Read the following instructions and take all necessary precautions

SHORT ARC XENON LAMPS AND SYSTEMS

Proper use and safe operating practices are the responsibility of equipment manufacturers who incorporate the lamp into equipment and users of such lamps and equipment. The supplier of this lamp provides information on its products and associated hazards, but it assumes no responsibility for after-sale operating and safety practices. All lamps are under pressure and must be handled with care. Take appropriate action through baffles, light shields, interlock switches or other safeguards to protect personnel from harm due to operation and/or failure of the lamp.

SAFE OPERATING INSTRUCTIONS

Do not operate this lamp except in accordance with proper operating instructions and within recommended operating specifications. Direct questions regarding lamp operation or safety to your lamp supplier.

LAMP DISPOSAL

CERMAX lamps do not have reclaimable parts. Before disposal, it is recommended to relieve a lamp's gas pressure by squeezing the tip-off with pliers until the gas escapes. If gas pressure is not relieved, care should be taken to discard the lamp in a landfill and not an incinerator.

SAFETY HAZARDS

The operation of lamps involves one or more of the following hazards. In the absence of safe operating practices and precautions, any one of these hazards could result in injury.

I. EXPLOSION - The lamps are filled with xenon gas at very high pressure. Lamps must be handled with the same care and caution given any vessel containing these levels of pressure. A hazard exists if the window or ceramic fractures and may cause explosive mechanical failure. Face shields or proper safety glasses are recommended during all handling operations.

II. HIGH VOLTAGE - Ignition voltage of some lamp models is very high and can be deadly. If portions of the circuit are exposed, caution must be used in setup and operation of the system. The input power must be disconnected from the power source before attempting any service to the lamp.

III. INFRARED AND ULTRAVIOLET RADIATION - Do not look directly at operating lamps or reflected light. Infrared and ultra violet radiation generated by the lamp can cause skin burns and permanent eye damage.

IV. OZONE - Some UV type lamps generate ozone, a toxic gas, by virtue of the ultraviolet radiation. A lamp which gives off ozone must be operated in a well ventilated area.

V. HOT SURFACES - Portions of the lamp can reach temperatures of several hundred degrees centigrade and cause serious burns if touched even after the lamp is turned off.

The SmartShutter is Not a Safety Shutter



WARNING

The Lambda LS can be optionally equipped with a Sutter Instrument SmartShutter. It is important for you to know that the SmartShutter is not intended to be a ‘safety shutter.’ A safety shutter usually closes automatically in the event of a power failure and is designed with the primary goal of ensuring that it will not allow any unintended exposure. For laser safety applications, a shutter is normally designed so that no single component failure allows an unintended exposure to the laser beam. The SmartShutter is intended for use in the controlling of light in scientific and industrial applications. The SmartShutter was designed for high performance and durability, but without certain features that would be desirable in a safety shutter application.

Avoiding Physical Injury and Equipment Damage while Replacing the Xenon Bulb



WARNING

Before removing the xenon arc lamp bulb housing assembly from a Lambda LS system, make certain that the system is powered down and disconnect the power cord from the source. Wait at least half an hour for the lamp to cool before removing the lamp bulb housing.

TABLE OF CONTENTS

DISCLAIMER	iii
SAFETY WARNINGS AND PRECAUTIONS	iii
Electrical	iii
Avoiding Electrical Shock and Fire-related Injury	iii
Operational	iv
Avoiding Physical Injury while Powered up and Emitting Light	iv
The SmartShutter is <u>Not</u> a Safety Shutter	vii
Avoiding Physical Injury and Equipment Damage while Replacing the Xenon Bulb.....	vii
1. GENERAL INFORMATION	1
1.1 Technical Support.....	1
2. INSTALLATION AND OPERATING INSTRUCTIONS	3
2.1 Unpacking.....	3
2.2 Assembly	3
2.2.1 Some Basic Information	3
2.2.2 Securing the Lambda LS to the Support Base	3
2.2.3 Determining the Appropriate Height.....	4
2.2.4 Light Guide Installation.....	5
2.2.5 Ozone Removal and Additional Venting	6
2.3 Filter Wheel and SmartShutter Installations	6
2.3.1 Use with No Filter Wheel Installed	6
2.3.2 Drop-In Filter Holder Use with No Filter Wheel.....	7
2.3.3 Use with a Single (Inner) Filter Wheel	8
2.3.4 Use with Two Filter Wheels	10
2.3.5 Use with a Standalone SmartShutter	11
2.4 Power Up	14
2.4.1 Line Power	14
2.4.2 Preparation and Precautions.....	14
2.4.3 Powering Up	15
3. MAINTENANCE	17
3.1 Routine Maintenance	17
3.2 Changing the Xenon Arc Bulb	17
3.2.1 Bulb Assembly	17
3.2.2 Removing the Lamp Assembly from the System	18
3.2.3 Bulb Replacement	19
3.2.3.1 Removing the Existing Bulb	19
3.2.3.2 Installing the New Bulb	19
3.2.4 Reinstalling the Lamp/Housing Assembly to the System.....	21
3.3 Filter Wheel and SmartShutter Maintenance	22
APPENDIX A. LIMITED WARRANTY	23
APPENDIX B. ACCESSORIES	25
B.1. Liquid Light Guides and Other Accessories	25
B.2. Microscope Mounting Adapters.....	25

B.3. Xenon Arc Lamp Bulbs	25
APPENDIX C. FUSE REPLACEMENT	27
APPENDIX D. TECHNICAL SPECIFICATIONS	29
INDEX.....	31

TABLE OF FIGURES

Figure 2-1. Securing the Lambda LS to the support base.	4
Figure 2-2. Liquid light guide installation.	5
Figure 2-3. Lambda LS with no filter wheel installed.	7
Figure 2-4. Lambda LS showing use of light tube in filter wheel cavity.	8
Figure 2-5. Light tube components.	8
Figure 2-6. Lambda LS with a single (inner) filter wheel.	9
Figure 2-7. Replacing the inner filter wheel.	10
Figure 2-8. Lambda LS shown with a second (outer) filter wheel installed.	11
Figure 2-9. Lambda LS installed with a standalone SmartShutter.	14
Figure 3-1. Bulb assembly components.	17
Figure 3-2. Removing the bulb assembly from the Lambda-LS.	18
Figure 3-3. Heat sink retaining-clip removal.	19
Figure 3-4. Bulb surfaces requiring they be covered with thermal compound.	20
Figure 3-5. Heat sink alignment and positioning of the retaining clips.	20
Figure 3-6. Position of the bulb/heat sink assembly in the blue housing.	21
Figure 3-7. Returning the bulb assembly to the system.	21
Figure 3-8. Fuse replacement.	27

1. GENERAL INFORMATION

The Lambda LS is a stand-alone xenon arc lamp light source system. The system consists of a xenon-arc lamp, lamp housing, cold mirror, and power supply. The Lambda LS is designed for use with a liquid light guide that transmits very flat, intense, illumination to the optical train of the user's microscope or other instrumentation. The lamp's cabinet accommodates a standard Sutter Instrument filter wheel that slides easily in and out of a slot in the light path. If desired, a second filter wheel can be mounted on the outside of the cabinet. When used with appropriate adapters, the light guide output is compatible with most common microscope systems (Nikon, Zeiss, Leica and Olympus).

Unlike the arc lamps used with most fluorescence microscopes, the xenon bulb is pre-aligned using a parabolic mirror and does not require alignment, focusing or collimation. In the standard configuration, the Lambda LS bulb is capable of producing light output from 340 nm to a cutoff of 700 nm determined by the cold mirror. An optional enhanced UV bulb produces output much lower into the UV (cut off near 200 nm). As with any UV-generating light source, the optional full-spectrum bulb generates significant quantities of ozone and must be used in an adequately ventilated environment.

The Lambda LS utilizes a compact design, which places power supply, lamp house, arc lamp, and cold mirror in a single enclosure. This system eliminates a common failure associated with standard arc lamp designs; when using a remote power supply aging may lead to a decreased ability to light the lamp due to loss of the insulating characteristics of the lengthy high-tension line. As with all our equipment, the power supply has been designed to minimize electrical noise that can be picked up by physiological recording equipment.

1.1 Technical Support

Sutter Instrument Company at no charge provides unlimited technical support to our customers. Our technical support staff is available between the hours of 8:00 AM and 5:00 PM (Pacific Time) at **(415) 883-0128**. You may also e-mail your queries to **info@sutter.com**. Furthermore, as this manual is currently under construction, if there are any areas that you feel should be covered in detail we would like to hear from you.

(This page intentionally blank.)

2. INSTALLATION AND OPERATING INSTRUCTIONS

2.1 Unpacking

The Lambda LS and associated hardware comes packed in a single carton. The following is a list of the components found there. If you believe that any of these components are missing or show obvious signs of damage from shipping, please contact the factory.

1. Lamp cabinet with factory-installed lamp, lamp housing, cold mirror, and power supply
2. One Support Base and two Mounting Rods
3. Power Cord
4. Manual
5. Second filter wheel adapter with drop-in filter holder and drop-in filter receptacle
6. Small Zeiss female dovetail
7. Liquid Light Guide dovetail with C-mount extension
8. Liquid Light Guide (if ordered)
9. Microscope adapters (if ordered)

If, in addition to the lamp, a Lambda filter wheel and one or more excitation adapters have been ordered, the wheel will have been installed in the filter wheel slot of the lamp prior to shipment. If a second wheel was ordered for excitation as well, it will be attached to the support bracket on the outside of the lamp. The filter wheel controller is packaged separately.

2.2 Assembly

2.2.1 Some Basic Information

The assembly directions for the Lambda LS vary considerably for different applications. The lamp is usually used with a liquid light guide. However, it is possible to direct the light directly into a microscope. The lamp can be used with either one or two filter wheels mounted; the first in the internal filter wheel slot and the second mounted on a bracket on the outside of the lamp. Setup is also dependent on the type of microscope in use. The following setup instructions cover general information required for all users followed by additional assembly directions for the various types of lamp configuration. Additional information specific to attachment of the light guide to your specific microscope is supplied with the liquid light guide adapter for your microscope.

2.2.2 Securing the Lambda LS to the Support Base

In most applications, the lamp will be mounted, via the mounting ears, to Support Rods attached to the Support Base. This assembly can be accomplished as follows:

1. Assemble the two Support Rods to the Support Base. Leave the rods loose at first.

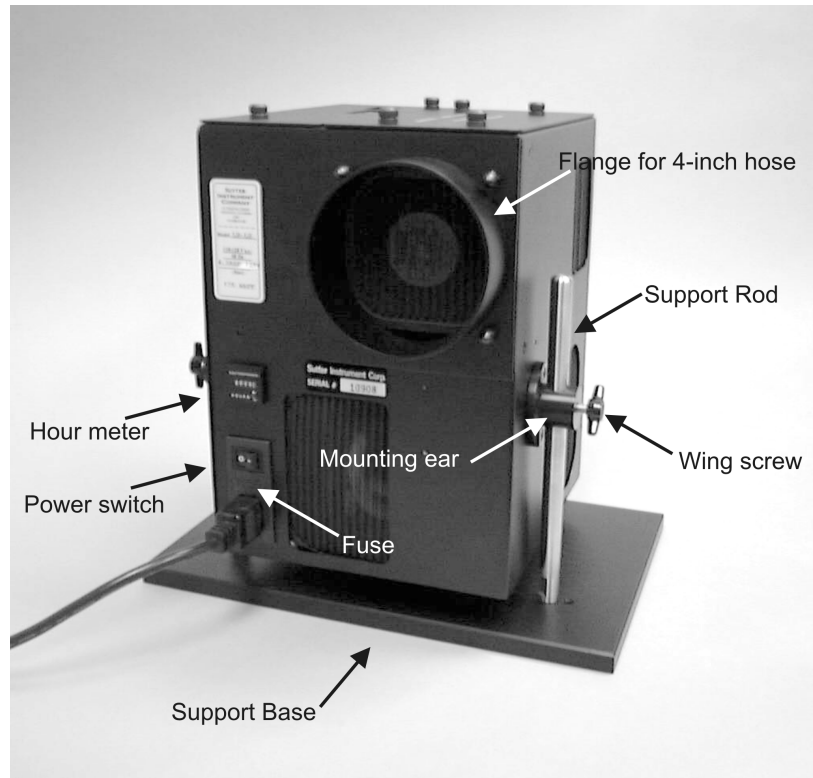

Figure 2-1. Securing the Lambda LS to the support base.

2. Loosen the wing screws and slide the Lambda LS mounting ears down over the Support Rods. As the tolerances are all quite precise, the two rods must enter the two mounting ears at the same time; when this is done correctly, the rods will slip easily into the ears. If you get one rod started without the other it is best to back it out and try again. Trying to force the second rod in will often cause further binding. Leaving the rods loose in the base and turning them as you lower the lamp helps to diminish binding. You may also find it easier to invert the lamp and the Support Base, and then slide the Support Rods into the mounting ears.
3. Once the lamp has reached the desired height, tighten the Support Rods firmly into the base. Flats have been machined near the threaded end of these rods to facilitate tightening with a wrench. Finally, tighten the wing screws.

2.2.3 Determining the Appropriate Height

If your Lambda LS is used in the standard configuration, with a light guide, then its height is unimportant. Ideally, it should be mounted less than one inch above the Support Base to provide maximal stability while still allowing a small space for airflow to maximize cooling of the bottom panel.

If your unit is to be used without a light guide, the position of the lamp cabinet on the Support Bars will be determined by the height of the light path into your microscope or other device. In some applications, the lamp may need to be higher than allowed by the standard height (8 inch) support bars. Support bars in 12- and 22-inch lengths are also available. In addition, the lamp cabinet may be installed upside down in order for the light output to accommodate very low light pathways.

2.2.4 Light Guide Installation

In the typical application, the collimated light output of the Lambda LS is focused onto the input end of a liquid light guide. The lamp's integral cold mirror allows the beam to be focused without danger to the light guide.

The liquid light guide has a black "end sleeve" preinstalled over the brass ferrule on each end. The two ends of the light guide are identical. The end sleeves are designed to slide into the mounting flanges on the input and output lens tubes.

The lens tube on the input end of the light guide comes with the guide and looks like that shown in the figure. The end sleeve slides into one end of the tube while the other end holds a UV-grade, fused-silica lens system (25.4 mm diameter, 33 mm focal length). The position of the sleeve in the tube can be later adjusted to optimize the light output from the light guide.

The lens tube slides into the dovetail tube. The dovetail tube is used to fasten the light guide and lens tube to the mating female adapter mounted either directly at the output of the lamp or at the output of a filter wheel (installed either internal or external to the Lambda LS cabinet).

The output lens system, at the opposite end of the light guide determines the characteristics of the output light. The output lens, lens tube, and mounting hardware are integral parts of the microscope adapter system when ordered for the liquid light guide. In many cases, the output parts are nearly identical to the input parts.

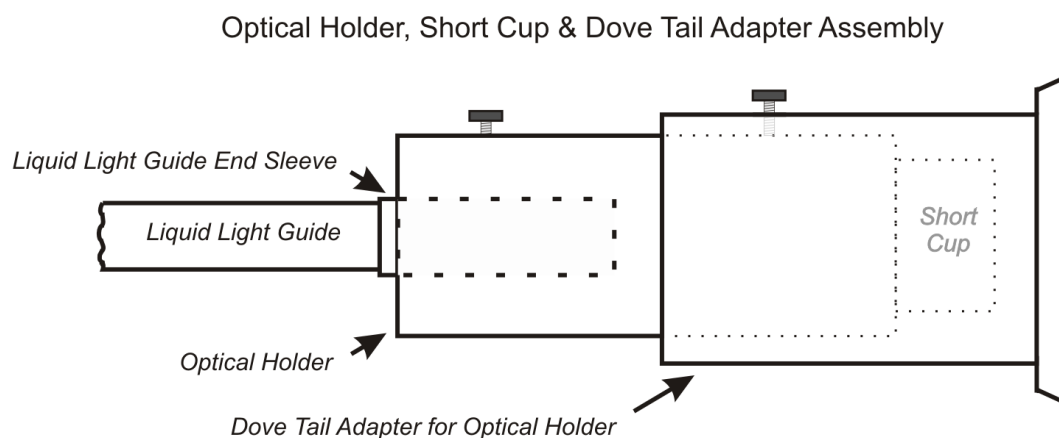

Figure 2-2. Liquid light guide installation.

The output lens functions to recollimate the beam. By correctly positioning the light guide sleeve in the output lens tube, the light guide output can be collimated (focused at infinity). This is most easily done by shining the light (preferably filtered to remove UV) at a uniform surface at least ten feet away and adjusting the position of the end of the light guide to a point where the light casts a well-focused circle on the distant surface. At 10 feet, this circle will be about 6 inches in diameter, have sharp edges, be uniform, and be quite brilliant if unfiltered.

The output lens tube is installed into one or more adapter pieces that mechanically and optically couple the light into the microscope. In external adapters, the adapter system mounts in place of the manufacturer's lamp house typically on the back of the microscope. In internal adapters, the adapter system is integral to the microscope, and the output lens is positioned inside the microscope as close as possible to the back of the filter cube-dichroic

mirror assembly. This arrangement makes the most efficient use of the collimated output beam.

Refer to documentation included with the individual microscope adapter for further installation instructions particular to the adapter.



CAUTION: PLEASE NOTE THAT THE LIGHT GUIDE HAS A MINIMUM-BENDING RADIUS OF 40 MM (ABOUT 1.6 INCHES).

2.2.5 Ozone Removal and Additional Venting

Unless your Lambda LS was ordered with UV producing full-spectrum bulb (LB-LS/FS17 or LB-LS/FS30) there is no need to vent ozone. In non-UV, ozone-free units (LB-LS/OF17 or LB-LS/OF30), it is in fact not desirable to attach a vent or venting hose to the supplied flange on the lamp. In many cases, use of a venting hose tends to diminish airflow and causes undue heating of the lamp leading to faster than normal bulb usage and in some cases damage to the power supply. **If you must use a venting hose, either to remove ozone in a UV producing unit, or to supplement heat removal in an ozone-free Lambda LS, you must make sure that there is a fan maintaining airflow through the venting hose!** Simply attaching a clothes-dryer style hose to the 4-inch fitting supplied on the side of the lamp will greatly impede the airflow of the internal fan and will cause the unit to overheat.

2.3 Filter Wheel and SmartShutter Installations

The Lambda LS was designed to be part of an excitation light source for fluorescence microscopy. As such, either one or two of Sutter Instrument filter wheels can be inserted into the light path with a minimum of intervention. Of course, if desired, the Lambda LS can be configured for use without a filter wheel. These three configurations are covered in this section.

2.3.1 Use with No Filter Wheel Installed

The simplest way to use the Lambda LS is with no filter wheel. In this configuration, the light guide and its input lens tube are positioned to sit as close as possible to the output of the bulb. The female dovetail and dovetail tube that hold the lens tube are threaded into a c-mount block that sits inside the Lambda LS body, in the slot that would normally carry the first filter wheel. The lens tube then is inserted into the dovetail tube from outside the lamp. In the figure below, which shows the dovetail tube mounted in this location, the cover over the filter wheel slot has been removed for viewing purposes. This cover should be in place when the lamp is in operation to minimize dust entry into the lamp.

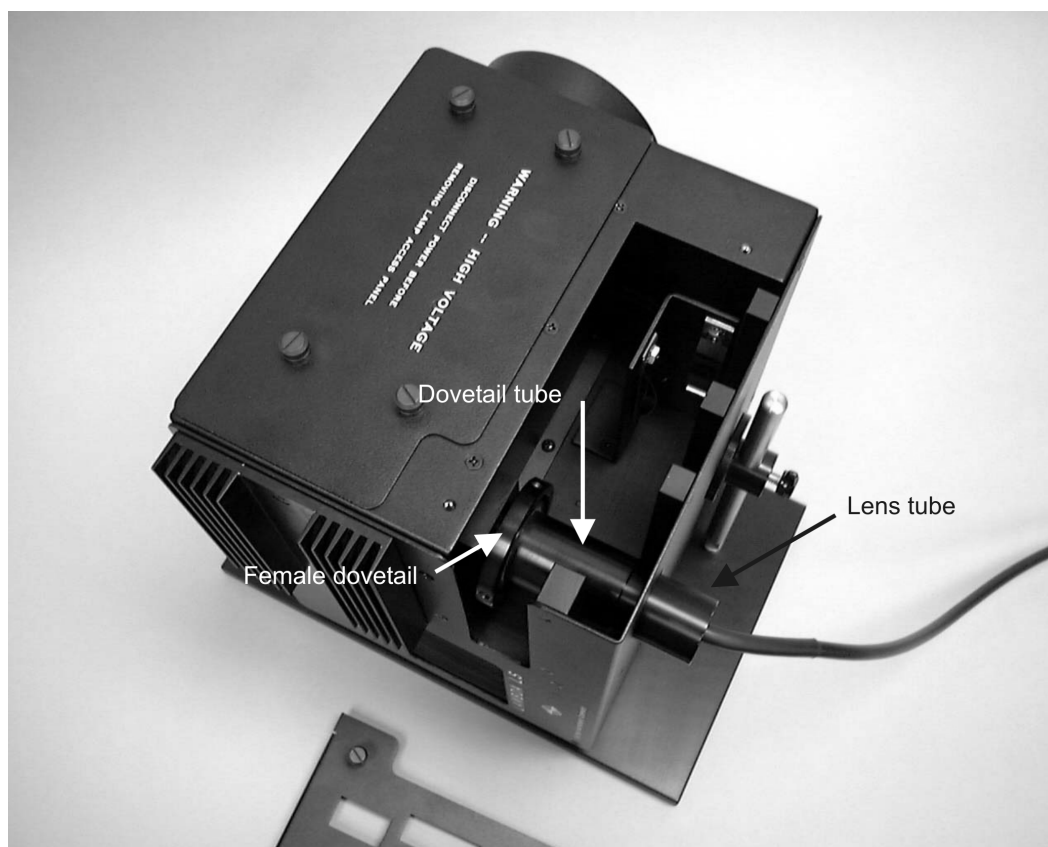

Figure 2-3. Lambda LS with no filter wheel installed.

An alternative connection is available which allows for a drop in filter holder to be positioned in the light path. This is useful for applications where there is need for a neutral density filter to decrease light output by a fixed amount. The drop-in filter holder sits in a c-mount block that sits on the outside of the lamp and the female dovetail and dovetail tube screw into this block. An additional female dovetail, dovetail tube, and c-mount tube are used to provide a light path across the inner pocket. These parts are included with each lamp and detail of their installation is given in the appendix.

2.3.2 Drop-In Filter Holder Use with No Filter Wheel

Often the user wishes to use a neutral density filter to limit light output or to provide for manual wavelength filtering when a filter wheel is not in use. We provide a mount for a single drop-in filter holder in the light path. The filter holder mounts on the outside face of the lamp for easy access. Outside, the lamp looks identical to the single internal filter wheel configuration that also uses the drop-in filter holder (see Figure 2-5). The internal filter wheel is absent however, and a light tube spans the inner cavity.

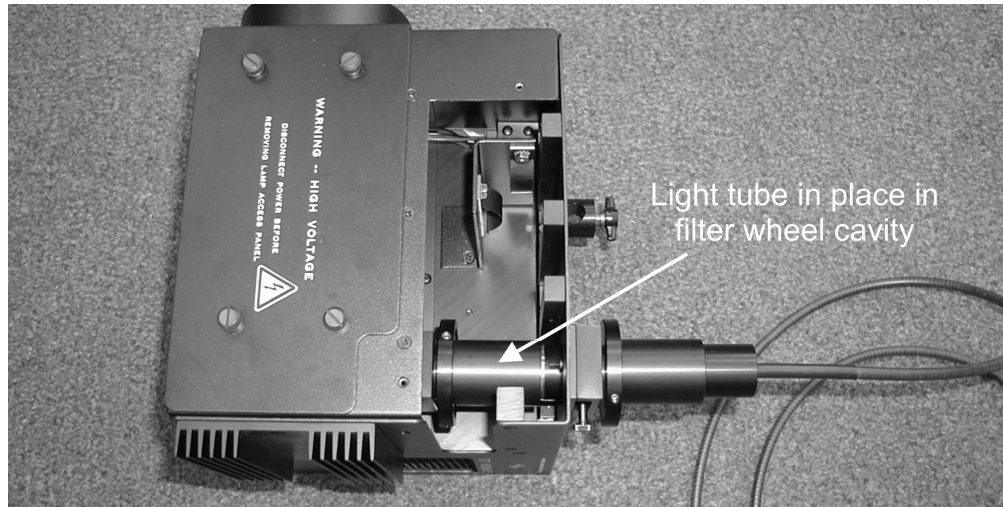

Figure 2-4. Lambda LS showing use of light tube in filter wheel cavity.

The light tube is formed from: 1) a female dovetail that threads into the inner c-mount in the lamp cavity, 2) a dovetail tube that is held in the female dovetail with three centering screws and 3) a c-mount tube that threads into the back of the outer c-mount/drop-in filter holder and telescopes into the dovetail tube to form a light path.

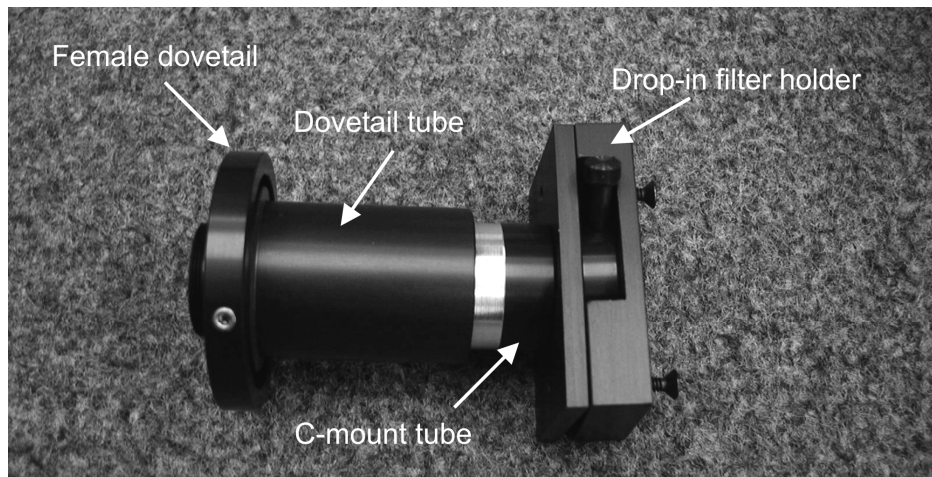

Figure 2-5. Light tube components.

To install the tube, first center and tighten the screws to hold the dovetail tube in the female dovetail. Next, thread the female dovetail into the inner c-mount. Then screw the c-mount tube into the back of the outer c-mount/drop-in filter holder. Finally, using the supplied screws, install the drop-in filter holder on the outside face of the lamp such that the c-mount tube telescopes into the dovetail tube.

2.3.3 Use with a Single (Inner) Filter Wheel

In many cases, the Lambda LS is ordered with a Sutter Instrument filter wheel. Furthermore, the lamp is often ordered to go with an existing filter wheel. The internal filter wheel can be easily removed to access the wheel for installation or removal of filters from the wheel. Once the wheel is installed in the pocket in the lamp, a cover is installed to protect the wheel and keep it firmly in place in the pocket. The wheel's DB-15 control cable attaches

through a hole in the cover. Note that any Lambda LS systems ordered with a single filter wheel is shipped with the filter wheel installed in the inner pocket.

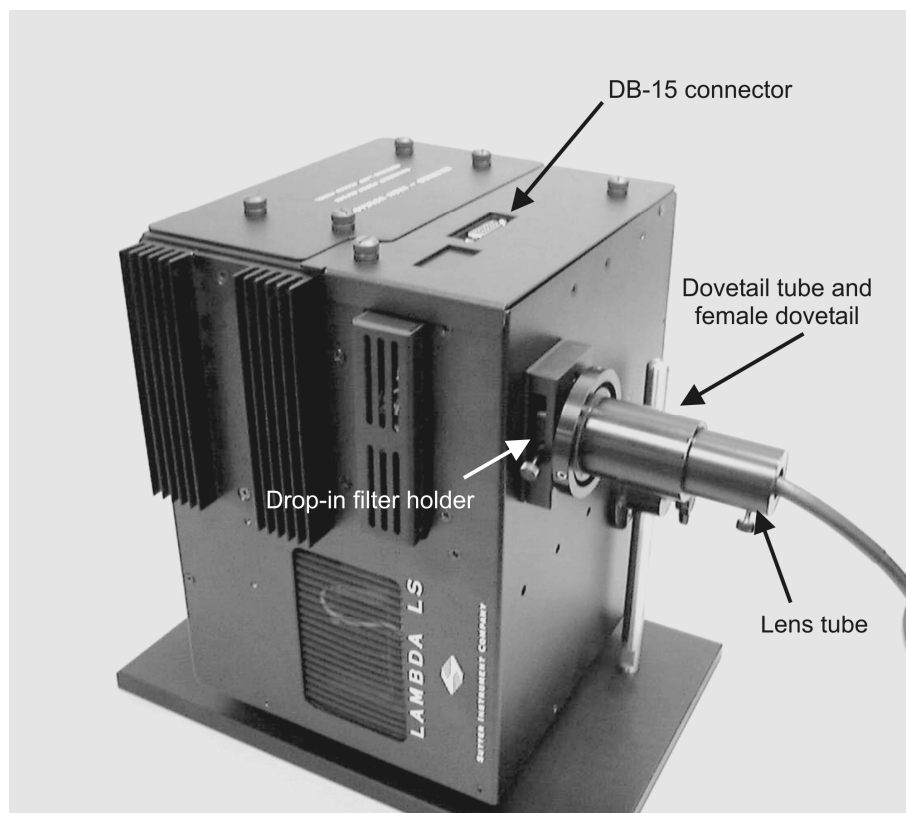

Figure 2-6. Lambda LS with a single (inner) filter wheel.

To install or remove the inner filter wheel first remove the cover by loosening the two thumb screws. To remove the wheel, you need to first use your finger or a small screwdriver or probe to gently free up the wire that runs to the shutter. Use care not to damage the wire with either too much force or a sharp tool. With this done, the filter wheel will lift straight up. Installation reverses this process. First, slide the filter wheel all the way down into the slot. The last $\frac{1}{4}$ inch of sliding may require some slight tilting of the wheel to get it to firmly seat in the pocket. If this wheel was not previously in the lamp, it may be necessary to first remove the “ears” that normally mount the wheel in non-Lambda LS applications and also remove the slide-in filter holders that are not accessible when the wheel is in the lamp. Once the wheel is fully inserted in the pocket, use your finger to tuck the shutter wire inside the slot between the wheel and the lamp. With the wire safely tucked in, replace the cover and attach the DB-15 cable connecting the filter wheel with the Lambda-series filter wheel controller.



Figure 2-7. Replacing the inner filter wheel.

2.3.4 Use with Two Filter Wheels

In some applications, it is desirable to have a second filter wheel in the light path. Generally, this wheel will have either neutral density filters or additional band-pass filters. The Lambda LS is designed to have a second filter wheel attached to a shelf on the outside of the lamp. If you ordered your lamp with two excitation wheels, then the second wheel was already attached to the shelf when it was shipped. If you are adding an additional wheel to the lamp, you must first attach the shelf using the supplied three (3) black, 10-32 x 1-inch flat head screws. The holes for these screws can be seen in the output side of the lamp about halfway down. In addition, if the lamp was originally configured for one filter wheel you will have to remove the female dovetail, dovetail tube and drop-in filter holder to allow the filter wheel access to the shelf. You may also have to remove the mounting “ears” from the wheel. The holes for the ears and associated 10-32 x 3/8 inch flat head screws are used to mount the outer wheel on the shelf. Finally, attach the female dovetail to the outer c-mount hole on the outer wheel.

If the wheel was installed at the factory, you will have to remove it to install filters. Simply remove the two screws that attach the wheel to the shelf.

If the outer wheel was not installed at the factory, it can be modified to minimize light leaks that will be present between the side of the lamp and the outer wheel. To do this thread a c-mount tube (supplied) into the threads on an inverted single drop-in filter holder mounted on the second wheel.

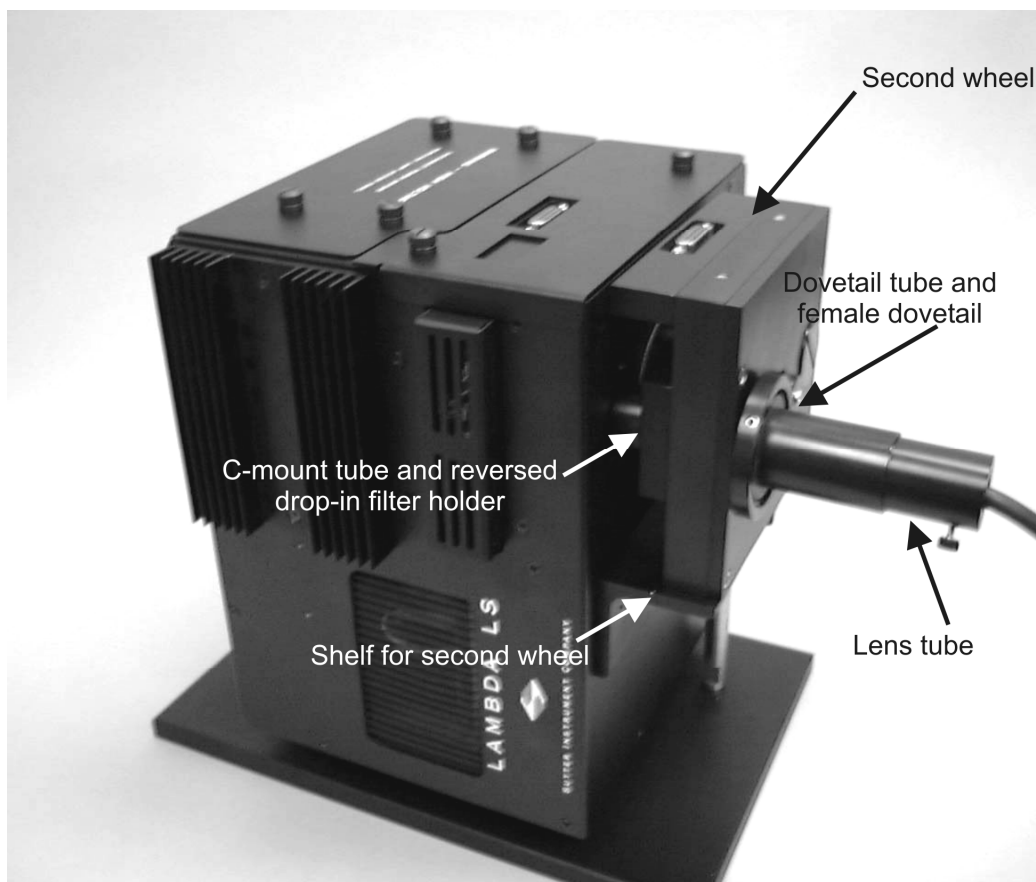
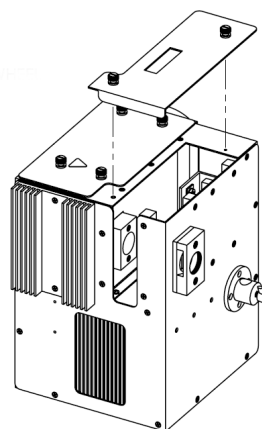

Figure 2-8. Lambda LS shown with a second (outer) filter wheel installed.

2.3.5 Use with a Standalone SmartShutter

The Lambda LS system's inner pocket can be equipped with a standalone SmartShutter (Model IQ25-LS) instead of a filter wheel. Like a filter wheel, the SmartShutter is externally controlled by a Sutter Instrument filter wheel/SmartShutter controller (Lambda 10-3 or Lambda 10-B) or a dedicated SmartShutter controller (Lambda SC). The following steps show how the standalone SmartShutter is installed in the inner pocket of the Lambda LS.

1. Remove Filter Wheel Cover Plate.



- Remove Drop-In Filter Holder by removing the two mounting screws.

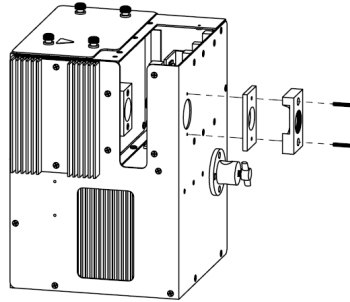

- Attach a male-to-male C-Mount to the SmartShutter with the dovetail portion on the outside.

NOTE: The part attached to the SmartShutter has three setscrews which are used to mount the dovetail when the part is fully threaded. Loosen the two most accessible setscrews (do not fully remove) and separate the two parts.

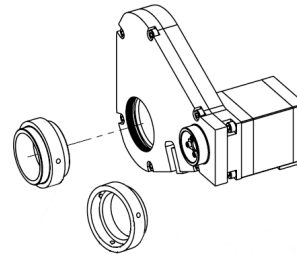

- Remove the dovetail.

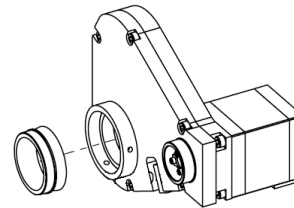

- Attach the dovetail to the C-Mount Block inside the cabinet.

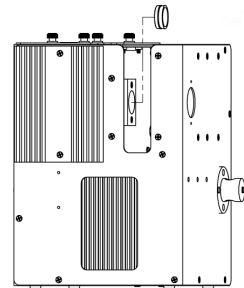

6. Insert the SmartShutter so the two parts of the C-Mount Adapter are aligned.

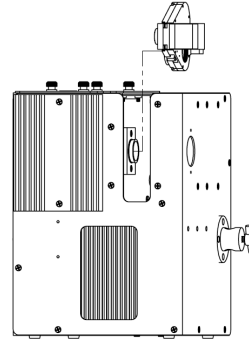

7. Tighten the two setscrews to mount the SmartShutter.

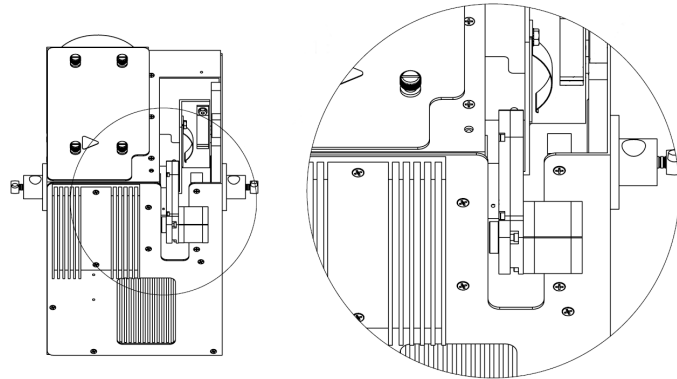

8. Attach the Extension Tube to the Filter Holder Back Plate and remount the Filter Holder Assembly.

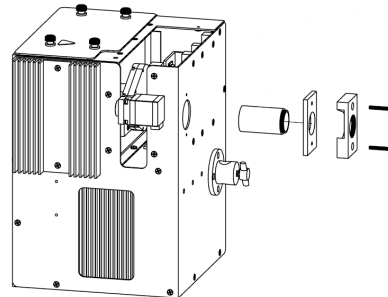

9. Reinstall the Cover Plate.

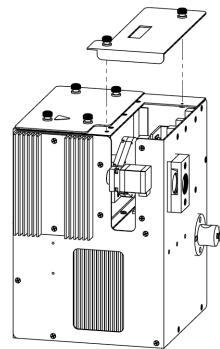

Once installed, the SmartShutter's motor will be shown extending through the gap on the side on to exterior of the cabinet. The standalone SmartShutter's 9-pin cable interface is also accessible through the gap on the side of the cabinet.

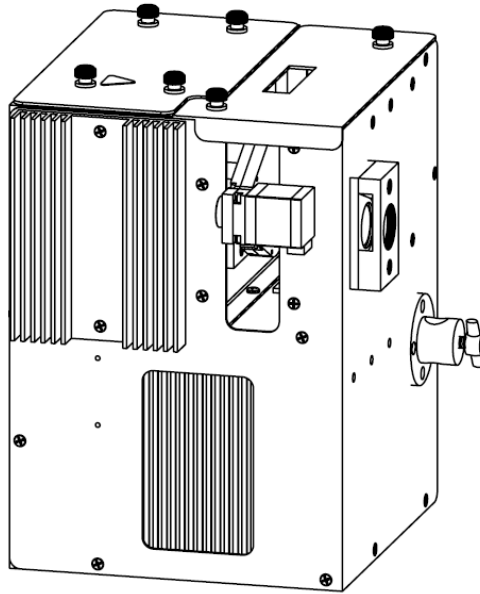

Figure 2-9. Lambda LS installed with a standalone SmartShutter.

2.4 Power Up

2.4.1 Line Power

The Lambda LS can be powered with either 110 or 220V. The unit automatically senses the voltage applied via the line cord and switches accordingly.

2.4.2 Preparation and Precautions

It is assumed that you have now completed attachment of your lamp to a microscope using some combination of filter wheels and a liquid light guide. It is not recommended that you power up the lamp until a solid, leak-free, light path has been established between the lamp cabinet and the microscope. The intensity and wavelengths of the light that can be produced by the Lambda LS are such that it should not be turned on unless the light is directed into a microscope and away from the eyes or skin of the operator or other nearby personnel. To reiterate:



WARNING: DO NOT LOOK DIRECTLY INTO THE LIGHT GUIDE! The output of the light or the light guide should be directed into the microscope using the appropriate adapters, directed away from anyone's eyes, and not directed toward any reflective surface.

Due to the current draw during lamp ignition, it is important to power up the Lambda LS first before other electronic and computer equipment, especially when they are powered from or grounded to the same circuit. Failure to do so may reset microprocessor-based equipment and/or may destroy sensitive operational amplifier-based instrumentation.

2.4.3 Powering Up

Once these precautions are understood, the Lambda LS may be powered by turning on the power switch located on the back panel (see Figure 2-1 on Page 4). The lamp should be expected to provide roughly 1000 hours of service. The hour meter will automatically record your total hours of lamp usage.

(This page intentionally blank.)

3. MAINTENANCE

3.1 Routine Maintenance

Routine cleaning of the Lambda XL system is required to prevent excessive dust accumulations. This is done by wiping all exterior surfaces with a dry, soft, cotton cloth. **To maintain the proper cooling of the lamp module and the electronic components inside the cabinet, keep the mesh screens covering the intake vents free of dust and place the unit away from any objects that could block the flow of cool air to the vents or deflect the flow of hot air back towards the vents.**

3.2 Changing the Xenon Arc Bulb

3.2.1 Bulb Assembly

The bulb assembly has the following components:

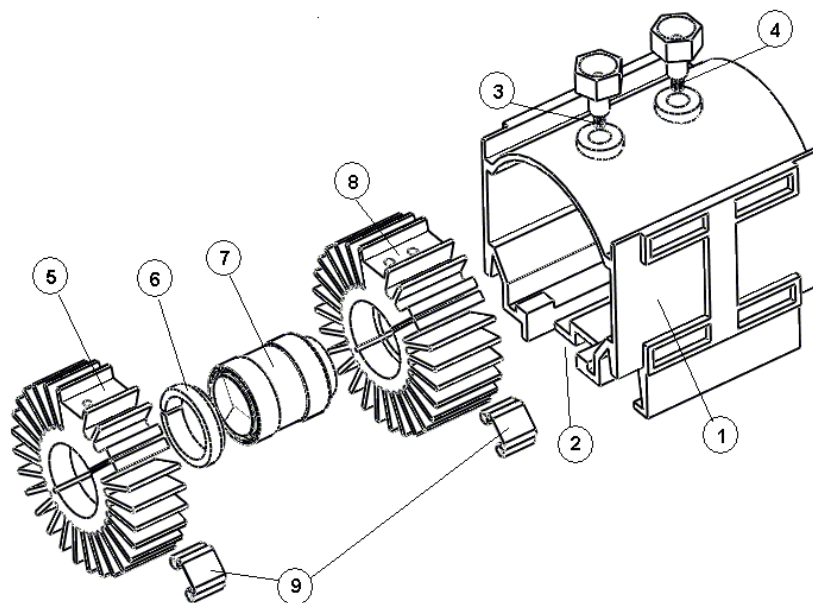

Figure 3-1. Bulb assembly components.

1. Blue lamp housing
2. Notch indicating the front (light output) side
3. Front terminal (smaller threads)
4. Rear terminal (larger threads)
5. Front (thinner) heat sink
6. Bulb mounting ring
7. Xenon Bulb

8. Rear (thicker) heat sink
9. Heat sink retaining clips

3.2.2 Removing the Lamp Assembly from the System



WARNING: Before removing the xenon arc lamp bulb housing assembly from the system, make certain that the system is powered down and disconnect the power cord from the source. Wait at least half an hour for the lamp to cool before removing the lamp bulb housing.

1. Locate the four thumbscrews that secure the lamp housing cover to the top of the lamp cabinet. This is the cover on which is affixed a warning label.
2. Unscrew the four screws and remove the cover panel to expose the blue plastic lamp housing assembly.
3. Grasp the sides of the housing and carefully pull it straight up and out of the cabinet.

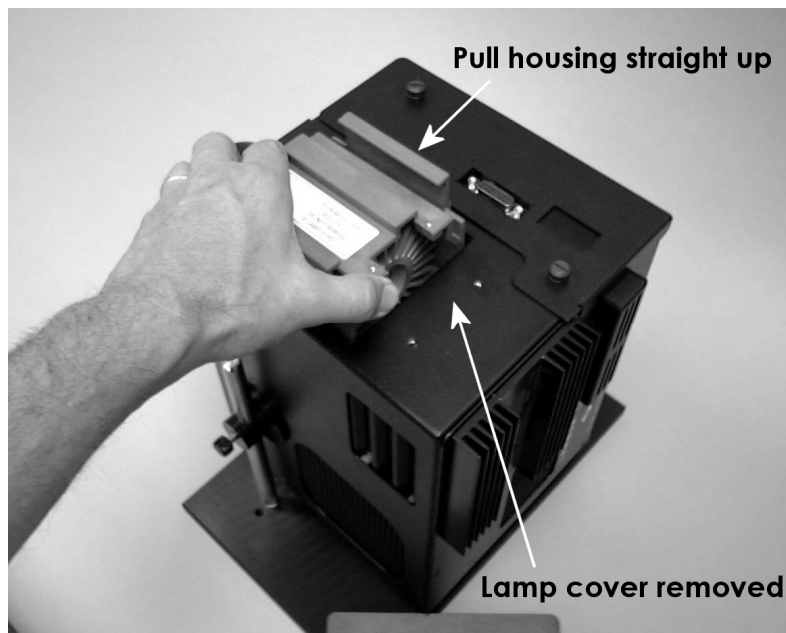

Figure 3-2. Removing the bulb assembly from the Lambda-LS.

3.2.3 Bulb Replacement

3.2.3.1 Removing the Existing Bulb

1. Remove both terminals (see Figure 3-1) from the blue housing.
2. Slide the bulb/heat sink assembly out from the blue housing.
3. Pry one of the retaining clips off one of the heat sinks and remove the heat sink. If the heat sink does not come off the bulb, insert a flat screw driver in the side slit of the heat sink and widen the gap (Figure 3-3) to remove the bulb. Repeat with the second heat sink.

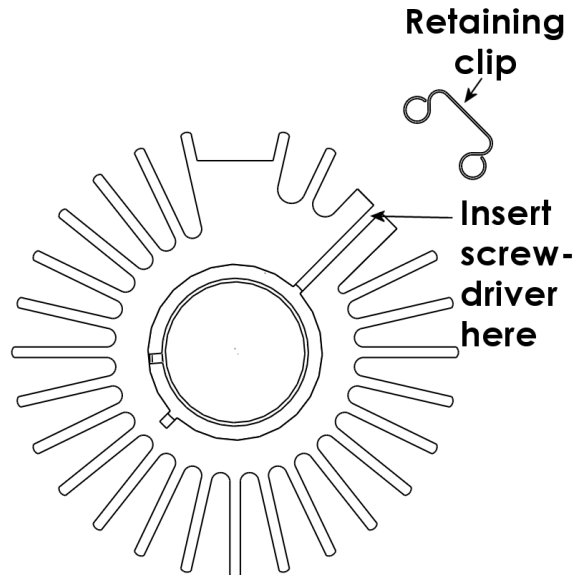

Figure 3-3. Heat sink retaining-clip removal.

4. Wipe off the white thermal compound from inside the heat sinks.
5. The mounting ring (see Figure 3-1) might still be inside the front heat sink. Remove it and set it aside. You will need it if the new bulb does not have one.

3.2.3.2 Installing the New Bulb

1. Without removing the protective cap from the new bulb, apply a thin, even layer of thermal compound to the side surfaces of the anode shell as shown in Figure 3-4.

⚠ CAUTION: *Avoid touching the sapphire window. If heat transfer compound is smeared on the window, it can be removed by gently wiping it off with a dry, lint-free tissue (lens paper or lens cloth).*

2. Slide the rear heat sink on the anode shell and press on or lightly tap the retaining clip, positioning it flush with the inside edge of the heat sink.

⚠ CAUTION: *Once the retaining clips are in place, the heat sinks should be tight enough not to slide around the bulb. If they still slide, remove the retaining rings, tighten them using a vice or adjustable pliers, and then reattach them on to the heat sinks.*

3. Remove the protective cap from the new bulb. If there is no mounting ring attached, use the ring from the old bulb. Apply a thin, even layer of thermal compound on the cathode shell on the surface shown in Figure 3-4. Slide on the front heat sink, align it with the rear heat sink (Figure 3-5) and press on the retaining clip positioning it flush with the inside edge of the heat sink.

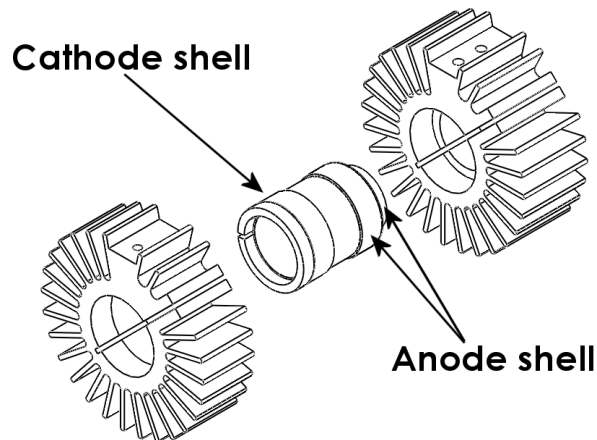

Figure 3-4. Bulb surfaces requiring they be covered with thermal compound.

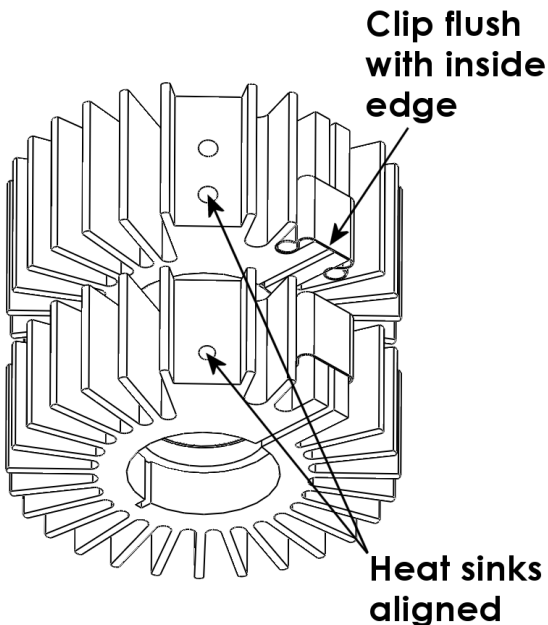

Figure 3-5. Heat sink alignment and positioning of the retaining clips.

4. Insert the heat sink/bulb assembly into the blue housing. Make sure the SAPPHIRE WINDOW side (output) is the same side as the notch in the blue housing (Figure 3-6). Screw in the terminals (the one located closer to the sapphire window has smaller threads than the other) slightly more than hand tight to complete the bulb installation in the blue housing.

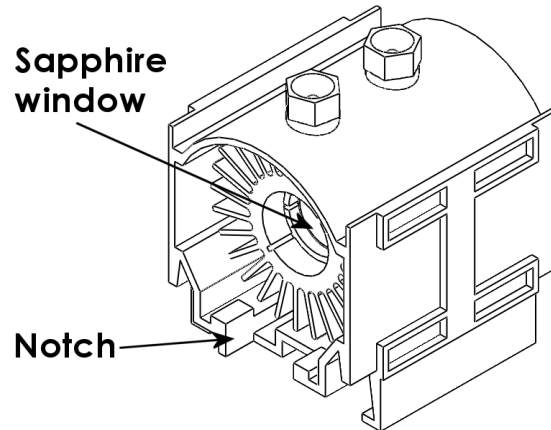

Figure 3-6. Position of the bulb/heat sink assembly in the blue housing.

3.2.4 Reinstalling the Lamp/Housing Assembly to the System

1. Grasp the sides of the housing and carefully lower it, terminals forward, into the cabinet. The sapphire window should point away from the lamp fan (Figure 3-7).
2. Reaffix the cover panel and screw it down with the four thumbscrews previously removed.

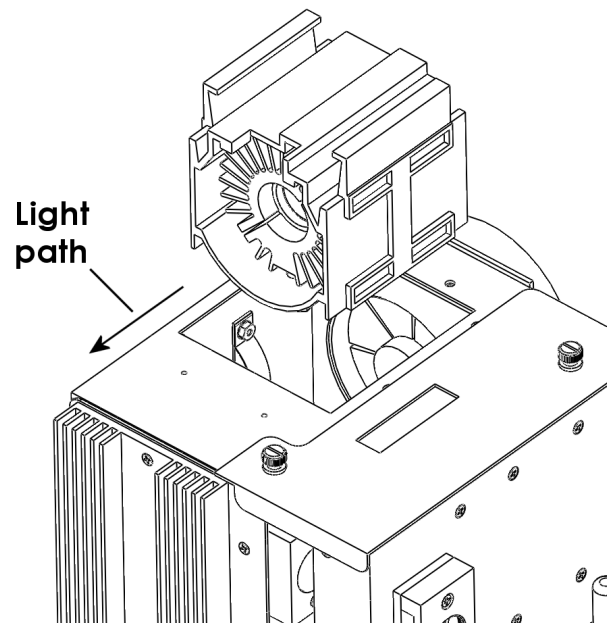

Figure 3-7. Returning the bulb assembly to the system.

3.3 Filter Wheel and SmartShutter Maintenance

All retaining rings should be inspected occasionally to be certain that they are seated into the filter holders and cups.



CAUTION: The filter wheel and SmartShutter are precision-machined parts, each mounted on a stepper motor shaft. As such, they DO NOT REQUIRE LUBRICATION. Attempting to lubricate any part of the filter wheel or SmartShutter assembly will void the warranty and may harm the motor or SmartShutter.

APPENDIX A. LIMITED WARRANTY

Sutter Instrument Company, a division of Sutter Instrument Corporation, limits the warranty on this instrument to repair or replacement of defective components for one year after the date of shipment, provided the instrument has been operated in accordance with the instructions outlined in the instruction manual. The CERMAX bulb is only covered for 500 hours.

Abuse, misuse, or unauthorized repairs will void this warranty.

Limited warranty work is performed only at the factory; the cost of shipment both ways is borne by the user.

This instrument is not intended for, nor should be used in, human experimentation or applied to humans in any way.

The limited warranty is as stated above and no implied or inferred liability for direct or consequential damages is intended.

(This page intentionally blank.)

APPENDIX B. ACCESSORIES

B.1. Liquid Light Guides and Other Accessories

LLG	Liquid light guide (2 meters, 3mm diameter), C-mount, lens and lens tube
LLG/380²	Liquid light guide (2 meters, 3mm diameter), C-mount, lens and lens tube. Allows light input into near IR.
DROP-IN	Drop-in filter holder (25mm diameter)

B.2. Microscope Mounting Adapters

Mounting adapters for Nikon, Zeiss, Leica and Olympus microscopes are available. Please refer to the Microscope Adapters section of Sutter Instrument's web site (<http://www.sutter.com>) for further information.

B.3. Xenon Arc Lamp Bulbs

The bulbs listed in the following do not include the outer blue housing. If an extra housing is required, please contact Sutter Instrument by phone, fax, or email.

O661176	175-Watt xenon arc lamp bulb, ozone free (attenuated output below 340nm)
O661175*	175-Watt xenon arc lamp bulb, full spectrum (<u>see warning below</u>)
O661301	300-Watt xenon arc lamp bulb, ozone free (attenuated output below 340nm)
O661300*	300-Watt xenon arc lamp bulb, full spectrum (<u>see warning below</u>)
O661115	Housing and heat sink for bulb (bulb will be installed when ordered at the same time as housing)

 *WARNING: Full-spectrum bulbs produce ozone, which is toxic and must be eliminated from the area in which the Lambda LS operates. Please be certain that you have proper ventilation – systems installed with full-spectrum bulbs must be connected to an ozone-removing device or system. Contact Sutter Instrument for more information.*

NOTE: For a full list of available accessories for the Lambda LS, refer to the Products section of Sutter Instrument's web site (<http://www.sutter.com>).

(This page intentionally blank.)

APPENDIX C. FUSE REPLACEMENT

In the event that the Lambda LS fails to power up when turning on its power switch, examine the line power fuse to see if it has blown. The fuse is located in a pry-out holder on the power entry module on the back of the lamp (see Figure 2-1 on Page 4). To remove the fuse holder first unplug the power cord from the power entry module. This will reveal a slot just under the edge of the fuse holder. Use a screwdriver to pry the holder straight out of the power entry module.

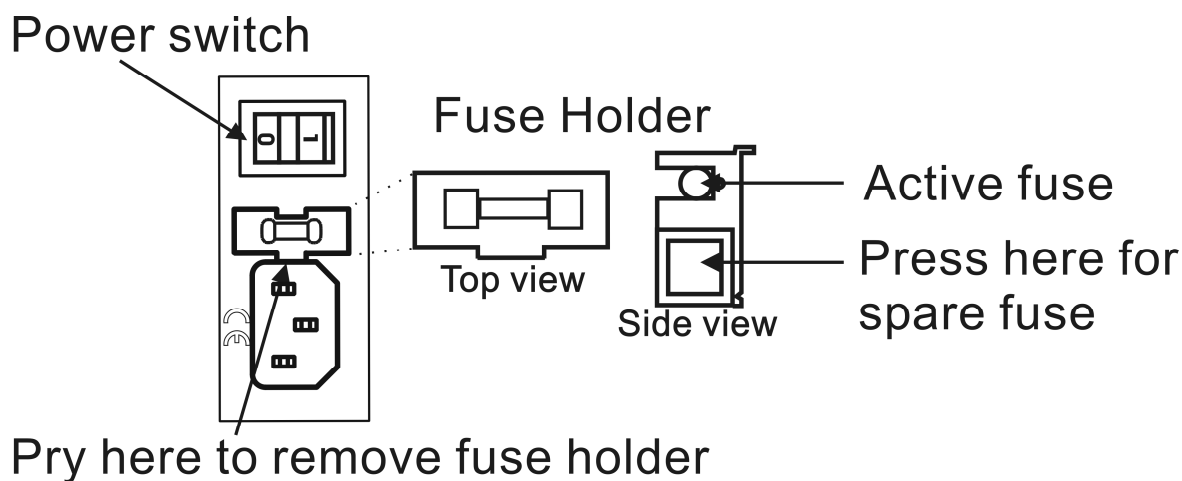

Figure 3-8. Fuse replacement.

The fuse that is readily visible in the fuse holder when you take it out is the one that is “active” when the holder is installed. A spare fuse is also stored within the fuse holder. It is concealed in a compartment as shown in the figure. To remove the spare fuse, press down on the end of the compartment and push it out of the other end. The old fuse can serve as a convenient tool for pushing the spare fuse compartment out. Replace the active fuse with the spare and re-install the fuse holder and power cord. If the lamp fails to power up with the new fuse installed, call Sutter Instrument technical support personnel for assistance. Replace with:

5 Amp, 250V, 5 x 20mm, Time Delay fuse (EIC 60127-2).
(Examples: Bussmann GDC-5A or S506-5A (RoHS), or
Littelfuse 218.005 or 218.005.P (RoHS))

(This page intentionally blank.)

APPENDIX D. TECHNICAL SPECIFICATIONS



Output Range:	200 to 700 nm (UV, ozone producing bulb) 320 to 700 nm (standard, ozone free bulb)
Radiant Output:	25 or 50 watts (broadband, full beam) for 175W or 300W bulb respectively ¹
Lamp Type:	175W or 300W Xenon arc, pre-aligned to produce collimated output
Lamp Life:	1000 hours (lamp warranted for 500 hours; expected lifetime: 1000 hours or more)
Dimensions (H x W x D):	10.5 x 9.5 x 10 in 26.7 x 24.1 x 25.4 cm
Weight:	10.5 lb. 4.8 kg
Electrical:	
Mains voltage:	110V through 240V, 50 through 60 Hz
Maximum power consumption:	300 W
Power cord:	10A, 250V, with safety ground plug
Mains fuse (rear of cabinet):	5 Amp, 250V, 5 x 20mm, Time Delay fuse (EIC 60127-2). (Examples: Bussmann GDC-5A or S506-5A (RoHS), or Littelfuse 218.005 or 218.005.P (RoHS))

¹ NOTE: The 125-Watt version of the Lambda LS is a discontinued product.

(This page intentionally blank.)

INDEX

A

accessories	25
bulbs.....	25
liquid light guides	25
microscope mounting adapters.....	25
other.....	25
assembly	3
some basic information	3

D

dimensions.....	29
disclaimer	iii
drop-in filter holder use with no filter wheel	7

F

filter wheel installation	6
fuse	
holder	27
location.....	27
replacement.....	27
spare.....	27
fuse replacement	iii, 27

fuses, replacement

mains	iii, 29
--------------------	---------

L

light guide	
installation.....	5

M

mains

fuses	iii, 29
power consumption	29
power cord	29
voltage.....	29
Maintenance.....	17
changing bulb.....	17
assembly	17
lamp assembly removal	18
reinstalling lamp housing to system	21
replacement	19
installing new bulb	19

removal	19
---------------	----

N

notes	
user.....	32

O

optical pathway	5
-----------------------	---

P

power	
connection	14
consumption.....	29
power cord	
mains.....	29
power entry module.....	27
power up	14
precautions	iii

S

safety warnings	iii
SmartShutter is not a Safety Shutter	vi
setting up.....	3
SmartShutter	11
standalone	11
installation.....	11
SmartShutter installation.....	6
support base	3
support rods	3

T

technical specifications.....	29
-------------------------------	----

U

unpacking	3
-----------------	---

V

voltage	
mains.....	29

W

warranty	23
weight	29

NOTES