



# SP101i Syringe Pump

Digital Infusion Syringe Pump

## INSTRUCTION MANUAL

Serial No. \_\_\_\_\_

052405

***World Precision Instruments, Inc.***

## Contents

GENERAL DESCRIPTION.....	2
SPECIFICATIONS.....	2
FEATURES.....	3
KEYPAD FUNCTIONS.....	3
DISPLAY.....	4
OPERATING INSTRUCTIONS.....	4
Power Switch.....	4
Main Menu.....	4
Syringe Diameter Entry.....	5
Volume Entry.....	5
Flow Rate Entry.....	6
Starting the Pump.....	6
Power Failure Mode.....	6
Change or Review Volume Setting While Running.....	7
Change or Review Rate Setting While Running.....	8
Fast Forward.....	8
LOADING THE SYRINGE.....	8
MANUAL STALL SETTING AND MICROLITER SYRINGES.....	9
NV RAM FAILURE.....	9
POWER SELECTION.....	9
MAINTENANCE.....	10
TABLE OF SYRINGE DIAMETERS.....	11
FLOW RATE TABLE.....	13
WARRANTY.....	14

## General Description

This manual applies to infusion pump, model **SP101i**. Operation of the pump is simplified by using a keypad to select features from a menu displayed on an alphanumeric LCD. All control functions are performed automatically by the pump microcontroller and are based on linear motion of the pusher block, associated with the syringe size (diameter) to deliver a known volume. After entering the syringe diameter, either directly or from a table in memory, all calibration and control functions are performed by the pump automatically.

## Specifications

Syringe Size	10 $\mu$ L to 10 mL (two), or 60 mL (one)
Voltage Operating Range	95-130, 220-260 VAC
Drive Mechanism	microprocessor controlled stepper motor 1/2 microstepping, driving a leadscrew through a belt and pulley drive mechanism
Pusher Advance per Half Step	0.66 micron
Minimum Stepping Rate	1 step/30 sec
Maximum Stepping Rate	400 half-steps/sec
Speed Range	6000:1
Flow Rate Range	0.001 $\mu$ L/min (10 $\mu$ L syringe) to 1.175 mL/min (60 mL syringe)
Linear Force	40 lb (18 kg)
Power	115/230 VAC, 60/50 Hz, internal selector switch
Fuse	5x20 mm, 250 V, 0.1 amp (slow-blow)
Dimensions	9 x 6 x 5 in. (23 x 15.25 x 13 cm)
Weight	5 lb (2 kg)

### Features

The SP101i is an accurate single syringe infusion pump designed to hold glass or plastic syringes, of any make, from 10 microliter to 60 milliliter.

Pump setup and operation is extremely simple. A menu, displayed on an alphanumeric LCD “prompts” the operator to make the necessary selections using the keypad for choice of features and numerical entries.

The **internal diameter of the syringe** is used by the control program to calibrate the pump and deliver the volume and flow rate selected. For simplicity the syringe diameter is also used to set volume and flow rate units.

The syringe diameter can be **entered directly** or the syringe can be identified from a **table of syringes** held in memory. When the syringe is selected from the table the diameter is entered automatically.

Two dispense modes are available:

- a) **dispense volume mode** in which the pump keeps track of the volume dispensed and automatically stops the pump when a set target volume is reached .
- b) **run mode** where the pump runs at the set flow rate until manually stopped .

In the event of a **power interruption** during operation, the pump can be programmed to either resume operation or remain stopped when power is returned.

For convenience, all pump **settings are stored in non-volatile memory** to minimize the number of setting changes required.

### Keypad Functions

- ← This key has two functions:
  - a. Moves the display to the left.
  - b. Causes the numerical entry to **decrease**. To change the displayed number by a single unit press and release the key quickly. If the key is pressed longer the number changes with increasing speed.
- This key has two functions.
  - a. Moves the display to the right.

- b. Causes the numerical entry to **increase**. To change the displayed number by a single unit press and release the key quickly. If the key is pressed longer the number changes with increasing speed.

**select** This key has three functions:

- a. Return to main menu when pressed repeatedly.
- b. Selects the pulsing or “highlighted” feature of the main menu display.
- c. Enter numerical values.

**run/stop** This key has two functions:

- a. Turns the motor on and off.
- b. Acts as a “pause” during a dispense.

## Display

After the pump is programmed an **arrow** on the right side of the display indicates the **direction of operation**. This arrow pulses when the pump is running.

## Operating Instructions

### Power Switch

The power switch is located at the right, rear corner of the pump. When the power is turned on the LCD will display the Volume or Rate setting. Press the **select** key to return to the main menu.

### Main Menu

Pressing **select** repeatedly will always return the display to the main menu. The main menu consists of five variables, three of which are displayed at all times. The center variable pulses to indicate that this option can be reviewed or changed. The menu acts as a continuous loop and the **arrow keys**, **← →** are used to move around the loop. The variable to be changed can be selected with the **select** key.

**← → DIA ← → TABLE ← → RATE ← → VOL ← → PWR UP ← →**

direct entry	syr dia.	flow rate	dispense vol	run/stop
syr dia (mm)	mfr, size	µl or ml/h	µl or ml	

## Syringe Diameter Entry

For automatic internal calibration the syringe diameter must be entered. Once entered the diameter is retained in non-volatile memory and need not be entered again unless the syringe used is changed. When a syringe diameter is changed the Volume and Rate settings are set to zero.

There are two methods of diameter entry.

### a. Internal library

Select **TABLE** from the main line menu. The table of syringes is organized by manufacturer, then by glass or plastic, and then by size. Use the **arrow** keys to scroll through the table and the **select** key to enter the correct setting.

First, scroll through the manufacturers and select the manufacturer of the syringe used. The menu will next display either material selection or a syringe size. Again, use the **arrow** keys to move through the table until the correct size is displayed. Press the **select** key when the correct syringe size is displayed. This automatically enters the internal syringe diameter.

See Table 1 at the end of this manual for the syringe library.

### b. Direct entry

From the main menu select **DIA**. The display will read “xx.xx mm”. Use the **arrow** keys to display the measured internal diameter of the syringe in millimeters and enter with the **select** key.

Changing the diameter clears the Volume and Rate settings, and the display will now prompt for the new Volume setting.

## Volume Entry

The Volume setting mode is selected from the main menu or is displayed automatically after changing the diameter.

Display reads: xx.xx  $\mu$ l (Units  $\mu$ l or ml depend on syringe diameter entered.)

- 1) Use the **arrow** keys to enter the dispense volume required.
- 2) When the correct dispense volume is displayed enter this number with the **select** key.

**note:** If no target dispense volume is required enter volume = 0.0 The pump will run at the set flow rate until stopped manually or a stall occurs.

- 3) After setting a Volume the menu prompts for the flow rate setting.

When the pump runs the actual dispensed volume will be displayed and will increment until the set volume is reached, at which time the pump will stop automatically.

### Flow Rate Entry

RATE can be selected from the main menu or will be displayed automatically after the Volume setting.

The display reads: Rate: X.X  $\mu$ l/h or X.X ml/h

Rate units are  $\mu$ l/h or ml/h, microliter or milliliter/hour and are selected automatically from the syringe diameter.

- 1) Use the **arrow** keys to display the flow rate required.
- 2) Enter the rate with the **select** key.
- 3) If the rate entered is out of range, a message is displayed "Max Rate XX ml/h" To continue enter a lower rate or select a larger syringe.

**note:** a. If a dispense volume was set then the display will now change to "Volume : 0.0" , that is, in automatic dispense mode.

When the pump runs, the actual dispensed volume will be displayed and will increment until the set volume is reached, at which time the pump will stop automatically.

b. If no dispense volume is set the LCD displays the set flow rate and, when running, the directional indicator arrow will pulse.

### Starting the Pump

- a. Press the **run/stop** key to start the pump. A second press will stop the pump.
- b. If the pump is stopped during a dispense the volume accumulator is not cleared and the dispense is *paused*. Restarting the pump with a second press of the **run/stop** key continues the dispense to the target volume.

### Power Failure Mode

When a dispense volume is set, a power interruption **always** stops the pump and resets the volume dispense counter to zero. The pump remains stopped when power is returned and displays either the Volume Setting (Pwr Stop mode) or

“Power Failed” flashing (Pwr Run mode). The pump can be restarted manually using the **run** or **select** keys respectively.

When no dispense volume is selected, the **Power Up run/stop** option allows the pump to either resume the dispense when the power returns or remain stopped but display a message that the dispense was interrupted.

1) Move the main menu to the right and select **PWR UP**.

2) The display will read **Power Up Run** ( or **STOP** ). Use the **arrow** keys to change display and **select** the required option.

**RUN** After power is returned the pump resumes normal operation. The display flashes **Power Failed** to acknowledge a power interruption. Press Select to display the Rate.

**STOP** Pump does not run when power returns. The LCD displays the rate setting; the directional indicator does not pulse.

### Change or Review Volume Setting While Running

While the pump is running it is possible to look at the volume and flow rate settings without interrupting the operation of the pump. If required the volume and flow rate settings can be changed while the pump continues to run. When the changes are entered the pump immediately changes to the new settings.

1) While operating press **select** to return to the main menu.

2) Select Volume to display the set dispense volume. If no change is required press **select**.

3) For a volume change the **arrow** keys can be used to change the setting which is entered with the **select** key.

4) The display moves to RATE, permitting a change if required. Press **select** if no change is required or use the **arrow** keys to change the setting. Pressing **select** returns the display to the continuing volume dispense and the pump immediately changes to the new flow rate, if changed. The volume continues to increment, uninterrupted to the new dispense setting when it will stop automatically.

**note:** If the VOLUME is changed to a setting **smaller** than the volume already accumulated then the pump stops when the new, smaller dispense volume is selected.



## Change or Review Rate Setting While Running

- 1) Press **select** to change the volume accumulator display to the main menu.
- 2) Select RATE.
- 3) Make rate changes if required and press **select**.

The pump immediately changes to the new flow rate and the display shows the volume accumulation continuing, uninterrupted at the new rate.

## Fast Forward

Press the **run** and the **→** keys simultaneously to actuate the fast forward mode. The pump travels at its maximum rate while both keys are pressed. If one key is deactivated the pump will stop and must be restarted with the **run** key.

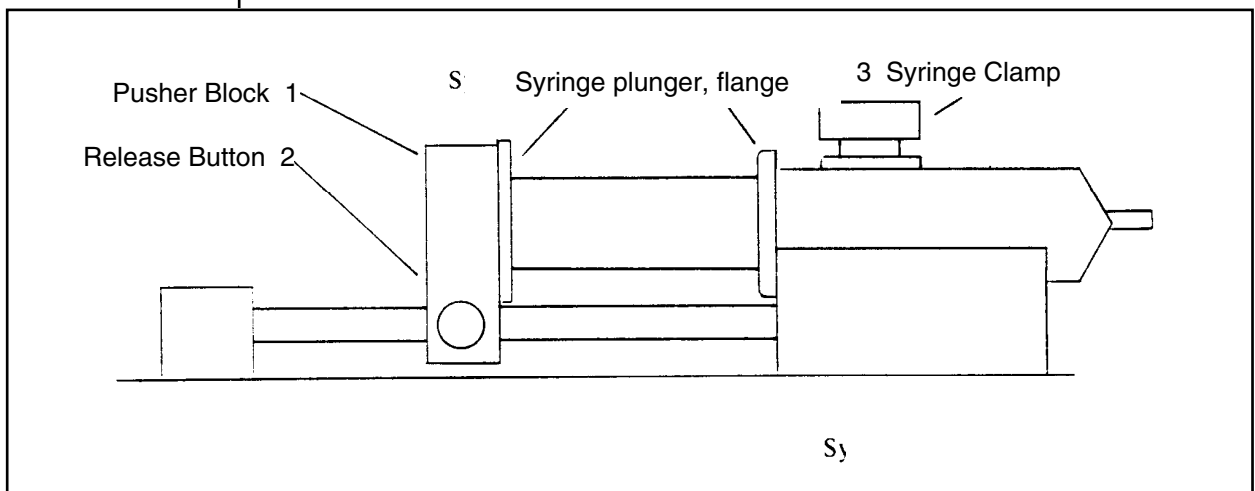

Figure 1

## Loading the Syringe

To facilitate loading, the pusher block (1) can be released from the leadscrew by pressing the bronze button (2) and manually moving it along the guide rods to accommodate the syringe.

Press the bronze button (2) on the side of the black pusher block (1) to release the block from the leadscrew.

While keeping the button (2) pressed firmly "in" slide the block along the guide rods to make way for the syringe plunger.

Raise the spring loaded retaining clamp (3) and rotate it away from the syringe barrel.

Place the syringe barrel in the V of the syringe holder, making sure that the flange of the syringe barrel is pressed against the side of the syringe holder.

Rotate and release the syringe clamp to hold the syringe in place.

Press in button (2) and move the pusher block back along the guide rods to make contact with the syringe plunger.

### **Manual Stall Setting and Microliter Syringes**

A movable collar located on the rear guide rod can be set to restrict travel of the pusher block. The block moves until stalling against the collar. Stalling does no permanent damage but may result in increased wear on the drive mechanism and should be used only as a “fail-safe” device.

Microliter syringes with fine wire plungers can be damaged if the plunger is forced into the end of the syringe barrel; the collar can be adjusted to prevent this occurrence.

### **NV RAM Failure**

If the settings in the non-volatile memory become corrupted the display will read “NV RAM Failure” and the pump will not operate.

To recover from this condition the pump must be powered down and then turned on again. The pump will be re-initialized to the default settings and can now be programmed as normal.

### **Power Selection**

The pump is equipped with an internal voltage selector switch which is set at the factory to the voltage appropriate for the destination country. The voltage setting is indicated on the serial number label found on the rear panel.

FUSE 5x20mm, 250V 0.1A (slow-blow)

### **Maintenance**

Maintenance is required only for the moving mechanical parts which should be kept clean and lubricated. Occasionally, a little light machine oil should be applied to the guide rods and a little grease or oil to the leadscrew.

Surface cleaning may be performed on the pump by using a dampened cloth, taking care that no excess cleaner be allowed to seep into the interior of the pump housing. *Do not use organic solvents.*

**Table 1 TABLE OF SYRINGE DIAMETERS**

**Air-Tite “All Plastic”**

1cc	4.70 mm
2.5	9.70
5.0	12.48
10	15.89
20	20.00
30	22.50
50	28.90

**Ranfac**

2 cc	9.12 mm
5	12.34
10	14.55
20	19.86
30	23.20
50	27.60

**Becton Dickinson**  
Interim, WW design, Plastipak

1 cc	4.70 mm
3	8.59
5	11.99
10	14.48
20	19.05
30	21.59
60	26.60

**Scientific Glass Engineering  
SGE**

25 µl	0.73 mm
50	1.03
100	1.46
250	2.30
500	3.26
1ml	4.61mm
2.5	7.28
5	10.30
10	14.57

**Becton Dickson**  
Glass — all types

0.5 cc	4.64 mm
1	4.64
2.5	8.66
5	11.86
10	14.34
20	19.13
30	22.70
60	28.60

**Sherwood - Monojet Plastic**

1 cc	4.65 mm
3	0.94
6	12.70
12	15.90
20	20.40
35	23.80
50	26.60

## SP101i Syringe Pump

---

### Hamilton 1000-Series Gastight

10 µl	0.46 mm
25	0.78
50	1.03
100	1.46
250	2.30
500	3.26
1 ml	4.61 mm
2.5	7.28
5	10.30
10	14.57
25	23.03
50	32.57

### Popper & Sons, Inc. Perfektum glass

0.25	3.45 mm
0.5	3.45
1	4.50
2	8.92
3	8.99
5	11.70
10	14.70
20	19.58
30	22.70
50	29.00

### Terumo

1 cc	4.73 mm
3	9.00
5	13.04
10	15.79
20	20.18
30	23.36
60	29.45

### Unimetrics Series 9000

10 µl	0.46 mm
25	0.73
50	1.03
100	1.46
250	2.30
500	3.26
1000	4.61

**Table 2 FLOW RATES**

<u>Syringe</u>	<u>Diameter*</u>	<u>Minimum</u>	<u>Maximum</u>
10 µl	0.48 mm	0.001 µl/m	0.382 µl/m
25 µl	0.73 mm	0.001 µl/m	0.884 µl/m
50 µl	1.03 mm	0.001 µl/m	1.762 µl/m
100 µl	1.46 mm	0.001 µl/m	3.542 µl/m
250 µl	2.30 mm	0.001 µl/m	8.78 µl/m
500 µl	3.26 mm	0.01 µl/m	17.65 µl/m
1 ml	4.70 mm	0.1 µl/m	36.6 µl/m
3 ml	8.59 mm	0.1 µl/m	122.5 µl/m
5 ml	11.99 mm	0.1 µl/m	238.8 µl/m
10 ml	14.48 mm	0.001 ml/m	0.347 ml/m
20 ml	19.05 mm	0.001 ml/m	0.602 ml/m
30 ml	21.59 mm	0.001 ml/m	0.773 ml/m
60 ml	26.60 mm	0.001 ml/m	1.175 ml/m

**\*NOTE:** This is a reference diameter used to compute the flow rate. The specific diameter should be entered for your syringe type.



## SP101i Syringe Pump

### Warranty

WPI (World Precision Instruments, Inc.) warrants to the original purchaser that this equipment, including its components and parts, shall be free from defects in material and workmanship for a period of one year\* from the date of receipt. WPI's obligation under this warranty shall be limited to repair or replacement, at WPI's option, of the equipment or defective components or parts upon receipt thereof f.o.b. WPI, Sarasota, Florida U.S.A. Return of a repaired instrument shall be f.o.b. Sarasota.

The above warranty is contingent upon normal usage and does not cover products which have been modified without WPI's approval or which have been subjected to unusual physical or electrical stress or on which the original identification marks have been removed or altered. The above warranty will not apply if adjustment, repair or parts replacement is required because of accident, neglect, misuse, failure of electric power, air conditioning, humidity control, or causes other than normal and ordinary usage.

To the extent that any of its equipment is furnished by a manufacturer other than WPI, the foregoing warranty shall be applicable only to the extent of the warranty furnished by such other manufacturer. This warranty will not apply to appearance terms, such as knobs, handles, dials or the like.

WPI makes no warranty of any kind, express or implied or statutory, including without limitation any warranties of merchantability and/or fitness for a particular purpose. WPI shall not be liable for any damages, whether direct, indirect, special or consequential arising from a failure of this product to operate in the manner desired by the user. WPI shall not be liable for any damage to data or property that may be caused directly or indirectly by use of this product.

### Claims and Returns

- Inspect all shipments upon receipt. Missing cartons or obvious damage to cartons should be noted on the delivery receipt before signing. Concealed loss or damage should be reported at once to the carrier and an inspection requested. All claims for shortage or damage must be made within 10 days after receipt of shipment. Claims for lost shipments must be made within 30 days of invoice or other notification of shipment. Please save damaged or pilfered cartons until claim settles. In some instances, photographic documentation may be required. Some items are time sensitive; WPI assumes no extended warranty or any liability for use beyond the date specified on the container.
- WPI cannot be held responsible for items damaged in shipment en route to us. Please enclose merchandise in its original shipping container to avoid damage from handling. We recommend that you insure merchandise when shipping. The customer is responsible for paying shipping expenses including adequate insurance on all items returned.
- Do not return any goods to WPI without obtaining prior approval and instructions (RMA#) from our returns department. Goods returned unauthorized or by collect freight may be refused. The RMA# must be clearly displayed on the outside of the box, or the package will not be accepted. Please contact the RMA department for a request form.
- Goods returned for repair must be reasonably clean and free of hazardous materials.
- A handling fee is charged for goods returned for exchange or credit. This fee may add up to 25% of the sale price depending on the condition of the item. Goods ordered in error are also subject to the handling fee.
- Equipment which was built as a special order cannot be returned.
- Always refer to the RMA# when contacting WPI to obtain a status of your returned item.
- For any other issues regarding a claim or return, please contact the RMA department.

*\* Electrodes, batteries and other consumable parts are warranted for 30 days only from the date on which the customer receives these items.*

**Warning: This equipment is not designed or intended for use on humans.**

## World Precision Instruments, Inc.

International Trade Center, 175 Sarasota Center Boulevard, Sarasota FL 34240-9258 USA  
Telephone: 941-371-1003 • Fax: 941-377-5428 • E-mail: sales@wpiinc.com

UK: Astonbury Farm Business Centre, Astonbury, Stevenage, Herts SG2 7EG UK • Tel: 0438-880025 • Fax: 0438-880026 • E-mail: wpiuk@wpi-europe.com  
Germany: Liegnitzer Str. 15 D-10999 Berlin, Germany • Tel: 030-6188845 • Fax: 030-6188670 • E-mail: wptide@wpi-europe.com